

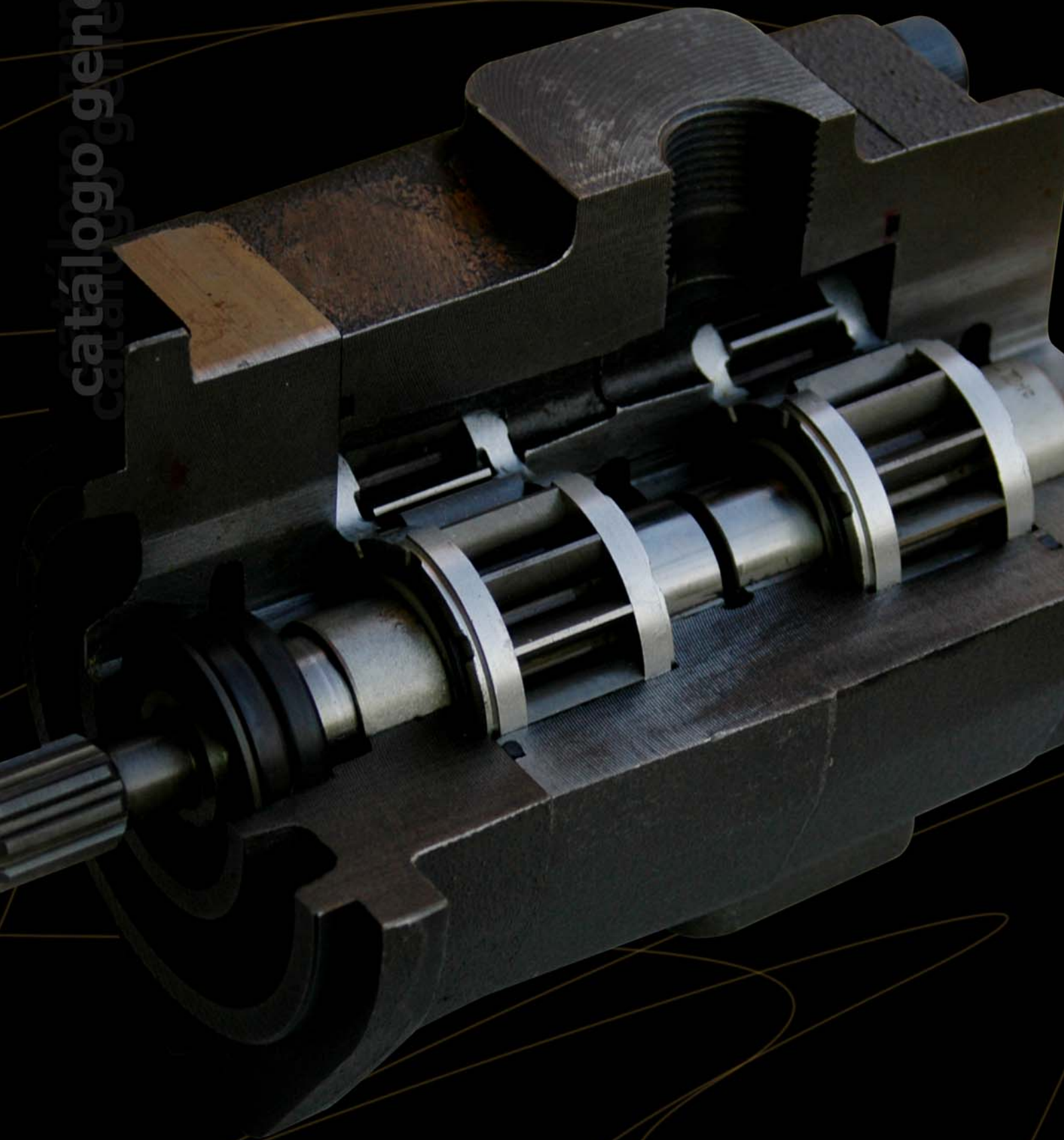





catálogo general



Roquet

Indice

	<i>Шестеренные насосы и моторы / Gear pump and motors</i>	4
	<i>Обратные клапаны / Check valves</i>	13
	<i>Распределитель многопоточный / Selector valves</i>	15
	<i>Клапаны давления / Pressure control valves</i>	18
	<i>Регуляторы расхода / Flow control valves</i>	27
	<i>Распределители / Control valves</i>	31
	<i>Распределители с электроуправлением / Solenoid operated</i>	39
	<i>Гидростанции / Hydraulic power pack units</i>	41
	<i>Цилиндры / Cylinders</i>	43
	<i>Гидромоторы орбитальные / Hydraulic motors</i>	45



Шестеренные насосы и моторы / Gear pump and motors

Система кодирования

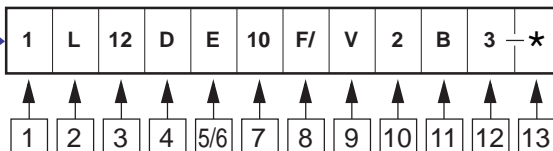

CODING SYSTEMS

1	Тип Type
1	Без шкива Without pulley
2	Со шкивом With pulley
5	Насос с дополнительным подшипником и плавающим валом Pump with back-up bearing and floating shaft
11	Шпоночный вал с дополнительным подшипником для монтажа на ZF Spline shaft with back-up bearing for mounting onto ZF
12	Шпоночный вал без дополнительного подшипника для монтажа на ZF Spline shaft without back-up bearing for mounting onto ZF
13	SAE B и C фланцы (2 отверстия) с дополнительным подшипником SAE B and C shaft (2 holes) with back-up bearing
14	SAE B и C фланцы (2 отверстия) без дополнительного подшипника SAE B and C shaft (2 holes) without back-up bearing
16	Раздельный вал для установки на ZF Shaft section for mounting onto ZF

Смотрите техническую информацию / See technical data for each type

2	Модель Model	(В обозначение мотора добавляется спереди буква M)	
Алюминиевые насосы / Aluminium pump		Чугунные насосы / Cast iron pumps	
M	0,33 - 1,33 cm ³	PNA	24 - 73,3 cm ³
LO	1 - 6,6 cm ³	PNC	53,3 - 150 cm ³
L	6 - 23,3 cm ³		
PLA	24 - 56 cm ³		
PLC	53,6 - 150 cm ³		

3	Расходы насосов даны при 1500 1/8= 200 OB< Pump flow rate at 1500 RPM a 0 bar
См техническую информацию / See technical data	

4	Направление вращения Rotation sense
D	По часовой / Clockwise
I	Против часовой / Counterclockwise
R	Ревверсивное / Reversible

5	Форма вала Driving shaft form
Алюминиевый насос Aluminium pump	A - B - C - E - F - G - H - J - Q - T
Чугунный насос Cast iron pumps	A - B - C - E - F - G - H - S - X

См техническую информацию / See technical data for each type

6	Тип блока Pulley type
P - R - S - T	

См техническую информацию / See technical data for each type

7	Тип фланца Fixing flange
04 - 06 - 09 - 10 - 13 - 19 - 20 - 21 - 22 - 23 - 29 - 55 - 61	

См техническую информацию / See technical data for each type

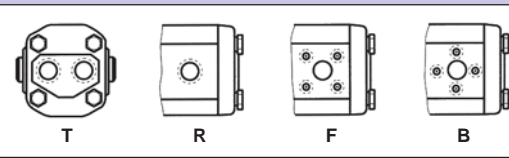
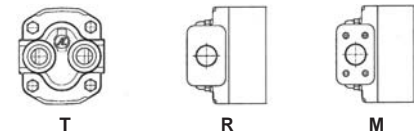
8	Виды присоединительных портов Port connection form
Алюминиевые насосы и моторы / Aluminium pump and motors	
	
	

9	Дополнительные функции Alternatives with valves
V	Предохранительный клапан Relief valve
VD	Предохранительный клапан и бак R. valve and tank
VC	Регулятор расхода с предохранительным клапаном Flow control valve with rel. valve
VCD	Регулятор расхода с предохранительным клапаном и баком Flow control valve with rel. valve and tank
RC	С приоритетом расхода Priority flow rate

См техническую информацию / See technical data for each type

10	Настройки предохранительного клапана Relief valve pressure setting		
Предустановки / Pre-set		Регулирование / Adjustable	
1	5 a 80 bar	11	5 a 80 bar
2	80 a 175 bar	12	80 a 175 bar
3	175 a 250 bar	13	175 a 250 bar

11	Объем бака Tank capacity	(только для типа L) (only type L pump)
A	Sin depósito	
B	1,5	
C	2,5	
D	3,8	

12	Постоянный/приоритетный расход Constant/primary flow	(только для типа RC) (only type RC pump)
1	5 l/min	
2	8 l/min	
3	12 l/min	
4	16 l/min	
5	22 l/min	
6	26 l/min	
7	28 l/min	

13	Дополнительные данные Additional data
-----------	---



Serie M



Datos técnicos hidráulicos Hydraulic technical data

CAUDAL BOMBA PUMP FLOW RATE (L./min.) 1500 r.p.m.	0,5	0,75	1	1,25	1,5	2
CILINDRADA DISPLACEMENT cm^3/v cc/r	0,33	0,5	0,66	0,83	1	1,33
PRESIÓN MÁX. CONTINUA EN CONT. MAX. PRESSURE	225					175
PRESION MAX. INTER. 5 SEG. MAX. INTERMITENT MAX. PRESSURE	250					200
R.P.M. A PRESIÓN CONTINUA RPM. AT CONT. PRESSURE	5000			4000		3000
R.P.M. MÁXIMAS MAX. R.P.M.	10000			8000		6000
MINIMAS R.P.M. SEGÚN PRESIÓN MIN R.P.M. AT GIVEN PRESSURES	100 bar	1000				
	150 bar	1500				
	250 bar	3000	2500		+	

Tapas anteriores Front covers

Tapa / Cover 09



SAE

Tapa / Cover 22



Formas conexión Tomas Port connection form

Tapa / Cover T



Tapa / Cover R



Diagrama de rendimientos volumétricos a 1.500 R.P.M. Volumetric efficiencies diagram at 1.500 R.P.M.

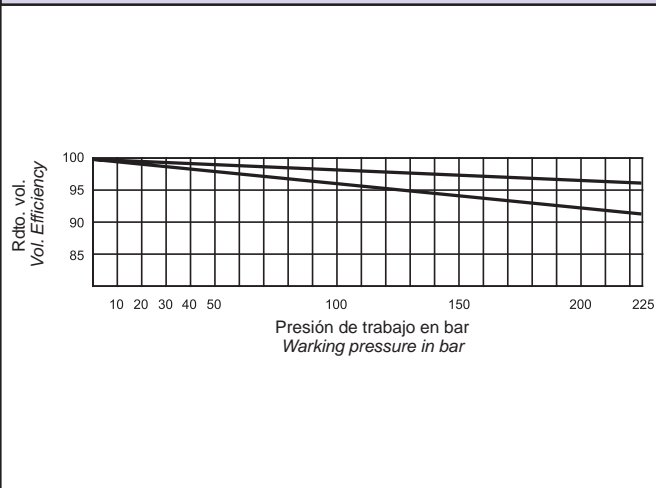

Ejes Shafts

Tipo / Type B



Tipo / Type F



DIN 9611

Tipo / Type E



Tipo / Type Q



Diagrama de caudales y potencias Flow rate and power diagram

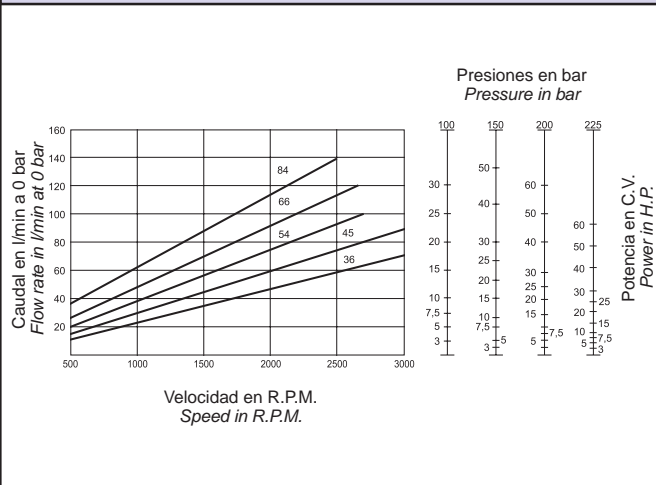

NOTA: Estos diagramas han sido obtenidos con un aceite de 5° E (37cSt) de viscosidad y una temperatura de 50° C

NOTE: These results have been obtained with 5° E (37cSt) viscosity oil and at 50° deg. C



Bombas de engranajes / Gear pump

Serie LO



Datos técnicos hidráulicos Hydraulic technical data

CAUDAL BOMBA PUMP FLOW RATE (L./min.)	1500 r.p.m.	1,5	3	5	7,5	10
CILINDRADA DISPLACEMENT	cm ³ /v cc/r.	1	2	3,3	5	6,6
PRESIÓN MÁX. CONTINUA EN CONT. MAX. PRESSURE	bar	275	240	185	135	
PRESION MAX. INTER. 5 SEG. MAX. INTERMITENT MAX. PRESSURE	bar	300	275	200	150	
R.P.M. A PRESIÓN CONTINUA RPM. AT CONT. PRESSURE		5000	4000	3000		
R.P.M. MÁXIMAS MAX. R.P.M.		6000	5000	4000	3000	
	100 bar	1000	750	500		
MINIMAS R.P.M. SEGÚN PRESIÓN	175 bar	1500	1250	1000	+	
MIN R.P.M. AT GIVEN PRESSURES	250 bar	2000	1750	1500	+	+
	300 bar	3000	2000	+	+	+

Tapas anteriores Front covers



Diagrama de rendimientos volumétricos a 1.500 R.P.M. Volumetric efficiencies diagram at 1.500 R.P.M.

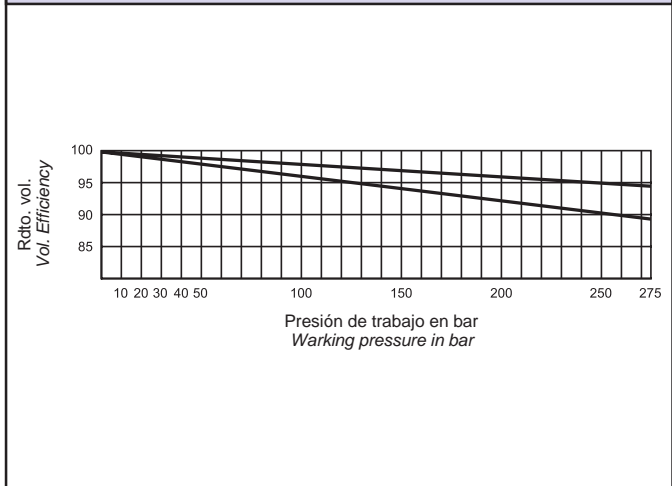

Formas conexión Tomas Port connection form



Diagrama de caudales y potencias Flow rate and power diagram



Ejes Shafts

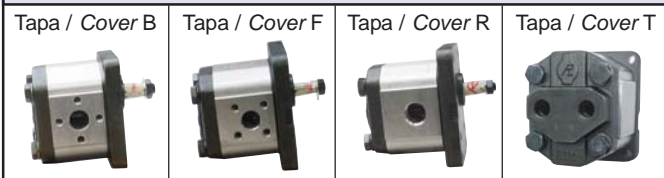
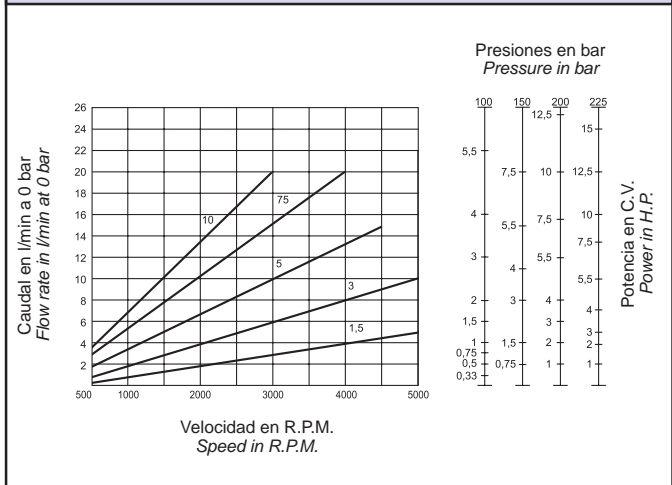
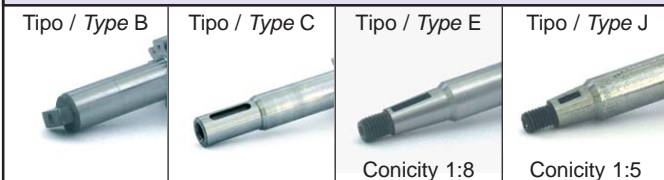

NOTA: Estos diagramas han sido obtenidos con un aceite de 5° E (37cSt) de viscosidad y una temperatura de 50° C
NOTE: These results have been obtained with 5° E (37cSt) viscosity oil and at 50° deg. C



Bombas de engranajes / Gear pump

Serie L



Datos técnicos hidráulicos Hydraulic technical data

CAUDAL BOMBA PUMP FLOW RATE (L./min.) 1500 r.p.m.	6	9	12	16	22	27	35	40
CILINDRADA DISPLACEMENT cm ³ /v cc/r.	4	6	8	10,6	14,6	18	23,3	26,5
PRESIÓN MÁX. CONTINUA EN CONT. MAX. PRESSURE bar	275			250		225	180	170
PRESION MAX. INTER. 5 SEG. MAX. INTERMITENT MAX. PRESSURE bar	300			275		250	210	200
R.P.M. A PRESIÓN CONTINUA RPM. AT CONT. PRESSURE	3500			3000		2500	2300	2000
R.P.M. MÁXIMAS MAX. R.P.M.	4000			3500		3200	3000	2500
	100 bar	500						
MINIMAS R.P.M. SEGÚN PRESIÓN	175 bar	1200	1100	850		750		
MIN R.P.M. AT GIVEN PRESSURES	250 bar	1400	1300	1200	1100	+	+	
	300 bar	1750	1500	+	+	+	+	

Tapas anteriores Front covers



Diagrama de rendimientos volumétricos a 1.500 R.P.M. Volumetric efficiencies diagram at 1.500 R.P.M.

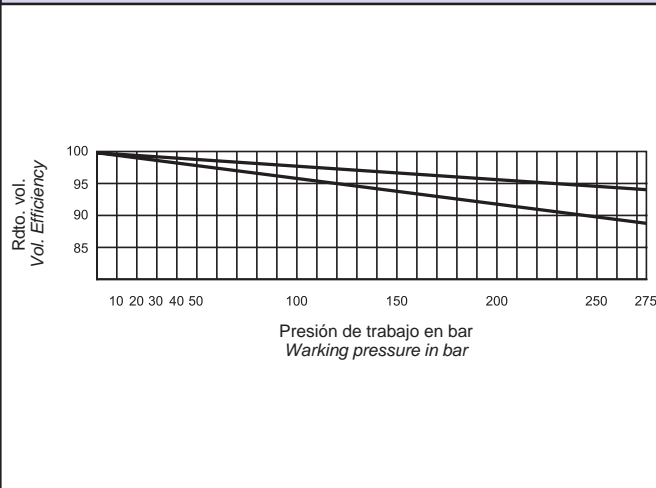

Formas conexión Tomas Port connection form



Diagrama de caudales y potencias Flow rate and power diagram



Ejes Shafts

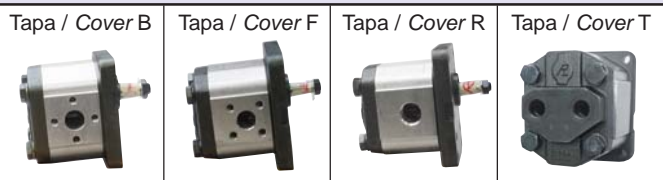
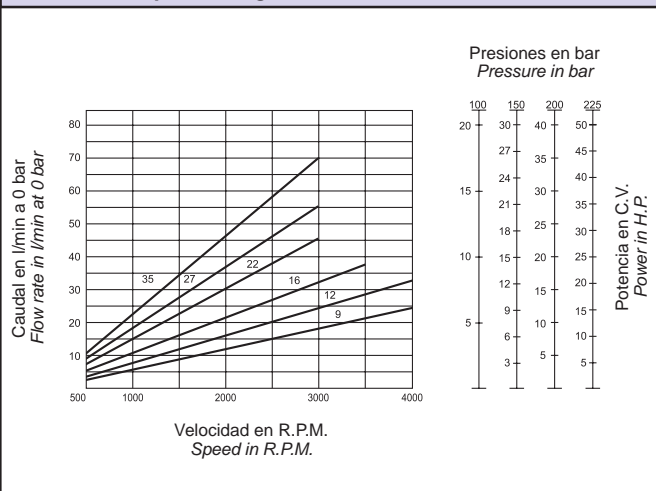
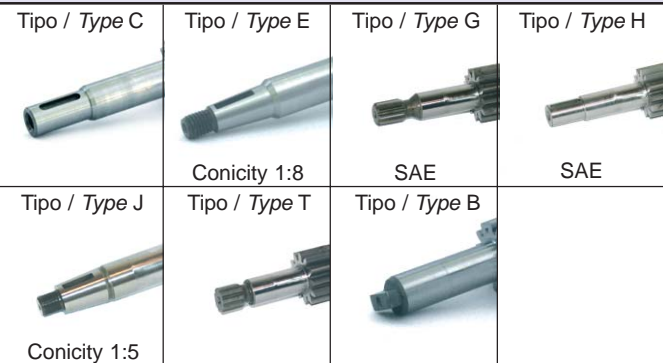

NOTA: Estos diagramas han sido obtenidos con un aceite de 5° E (37cSt) de viscosidad y una temperatura de 50° C

NOTE: These results have been obtained with 5° E (37cSt) viscosity oil and at 50° deg. C



Serie PLA



Datos técnicos hidráulicos Hydraulic technical data

CAUDAL BOMBA PUMP FLOW RATE (L./min.) 1500 r.p.m.	36	45	54	66	84
CILINDRADA DISPLACEMENT cm ³ /v cc/r	24	30	36	44	56
PRESIÓN MÁX. CONTINUA EN CONT. MAX. PRESSURE bar	250	225	200	175	
PRESION MAX. INTER. 5 SEG. MAX. INTERMITENT MAX. PRESSURE bar	275	250	225	200	
R.P.M. A PRESIÓN CONTINUA RPM. AT CONT. PRESSURE	2500	2300	2200		
R.P.M. MÁXIMAS MAX. R.P.M.	3000	2800	2600		
MINIMAS R.P.M. SEGÚN PRESIÓN	100 bar	500			
MIN R.P.M. AT GIVEN PRESSURES	175 bar	800	700	600	
	250 bar	1500	900	+	+

Tapas anteriores Front covers



Diagrama de rendimientos volumétricos a 1.500 R.P.M. Volumetric efficiencies diagram at 1.500 R.P.M.

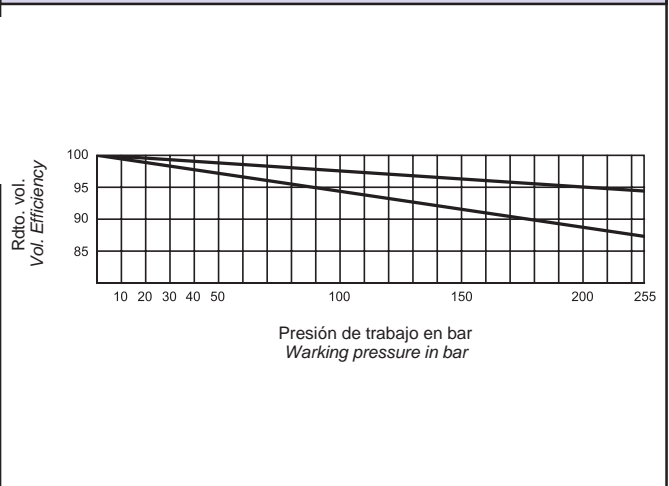

Formas conexión Tomas Port connection form



Diagrama de caudales y potencias Flow rate and power diagram



Ejes Shafts

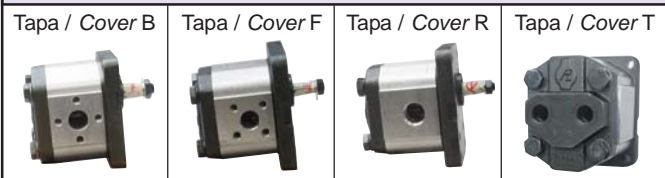
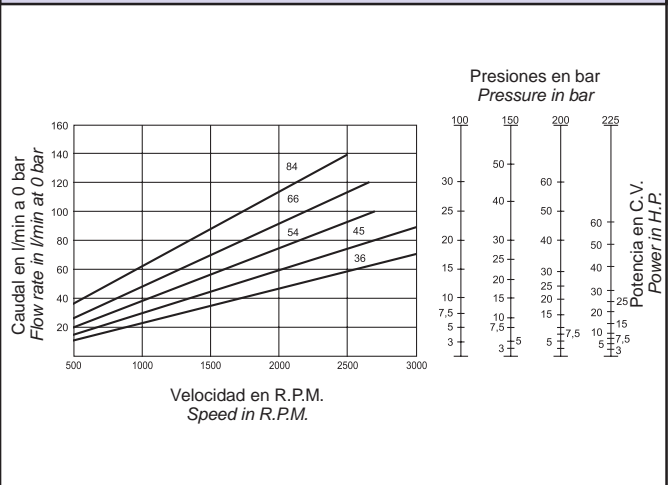
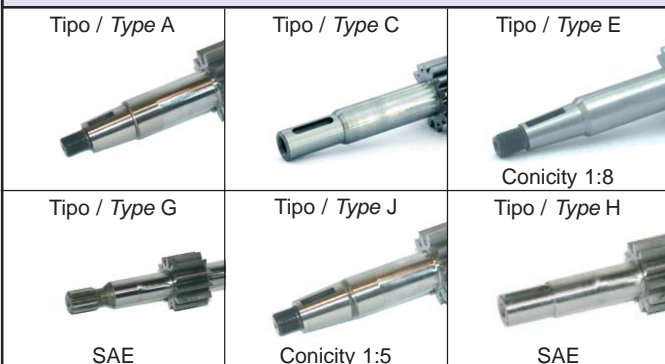

NOTA: Estos diagramas han sido obtenidos con un aceite de 5° E (37cSt) de viscosidad y una temperatura de 50° C
NOTE: These results have been obtained with 5° E (37cSt) viscosity oil and at 50° deg. C



Serie PLC



Datos técnicos hidráulicos Hydraulic technical data

CAUDAL BOMBA PUMP FLOW RATE (L./min.) 1500 r.p.m.	80	100	125	150	175	200	225
CILINDRADA DISPLACEMENT cm ³ /v cc/r	53,6	66,6	83,3	100	116,6	133,3	150
PRESIÓN MÁX. CONTINUA EN CONT. MAX. PRESSURE bar	250		225		200	175	
PRESION MAX. INTER. 5 SEG. MAX. INTERMITENT MAX. PRESSURE bar	275		250		225	200	
R.P.M. A PRESIÓN CONTINUA RPM. AT CONT. PRESSURE							
R.P.M. MÁXIMAS MAX. R.P.M.	3000		2500		2000	1750	
MINIMAS R.P.M. SEGÚN PRESIÓN	100 bar	400		350			
	175 bar	500		400			
MIN R.P.M. AT GIVEN PRESSURES	250 bar	650	+	+	+	+	

Tapas anteriores Front covers

Tapa / Cover 01



Tapa / Cover 09



Tapa / Cover 10



Tapa / Cover 23



Formas conexión Tomas Port connection form

Tapa / Cover B



Diagrama de rendimientos volumétricos a 1.500 R.P.M. Volumetric efficiencies diagram at 1.500 R.P.M.

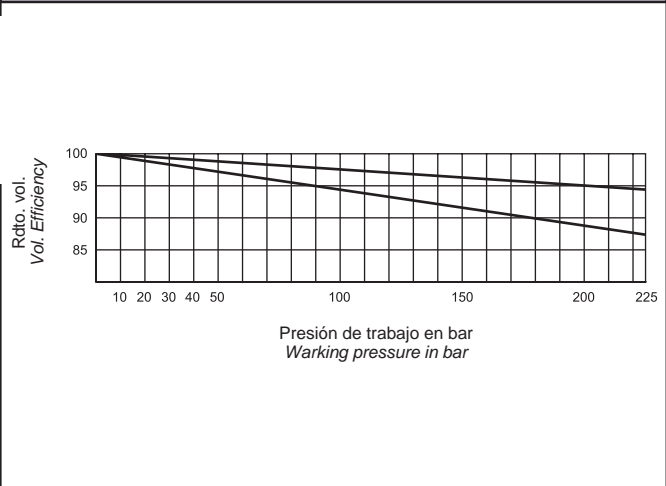

Ejes Shafts

Tipo / Type A



Tipo / Type C



Tipo / Type E



Conicity 1:8

Tipo / Type G



SAE

Tipo / Type J



Conicity 1:5

Tipo / Type H



SAE

Diagrama de caudales y potencias Flow rate and power diagram

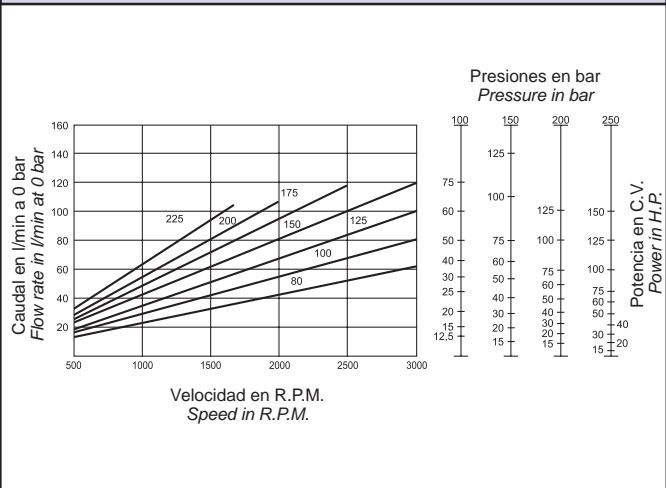

NOTA: Estos diagramas han sido obtenidos con un aceite de 5° E (37cSt) de viscosidad y una temperatura de 50° C
NOTE: These results have been obtained with 5° E (37cSt) viscosity oil and at 50° deg. C



Bombas de engranajes / Gear pump

Serie PNA



Datos técnicos hidráulicos Hydraulic technical data

CAUDAL BOMBA PUMP FLOW RATE (L./min.) 1500 r.p.m.	36	45	54	66	84	96	110
CILINDRADA DISPLACEMENT cm ³ /v cc/r	24	30	36	44	56	64	73,3
PRESIÓN MÁX. CONTINUA EN CONT. MAX. PRESSURE bar	270	260	210	180	160		
PRESION MAX. INTER. 5 SEG. MAX. INTERMITENT MAX. PRESSURE bar	300	285	250	225	200		
R.P.M. A PRESIÓN CONTINUA RPM. AT CONT. PRESSURE							
R.P.M. MÁXIMAS MAX. R.P.M.		3000	2500	2000	1750		
MINIMAS R.P.M. SEGÚN PRESIÓN	100 bar	400	350				
	175 bar	450	350				
MIN R.P.M. AT GIVEN PRESSURES	250 bar	550	-	-	-		

Tapas anteriores Front covers

Tapa / Cover 09



SAE

Tapa / Cover 10



Tapa / Cover 50



Formas conexión Tomas Port connection form

Tapa / Cover P



Tapa / Cover R



Tapa / Cover M



SAE

Ejes Shafts

Tipo / Type B



Tipo / Type C



Tipo / Type E



Conicity 1:8

Tipo / Type G



SAE

Tipo / Type H



SAE

Tipo / Type X



Diagrama de rendimientos volumétricos a 1.500 R.P.M. Volumetric efficiencies diagram at 1.500 R.P.M.



Diagrama de caudales y potencias Flow rate and power diagram



NOTA: Estos diagramas han sido obtenidos con un aceite de 5° E (37cSt) de viscosidad y una temperatura de 50° C
NOTE: These results have been obtained with 5° E (37cSt) viscosity oil and at 50° deg. C

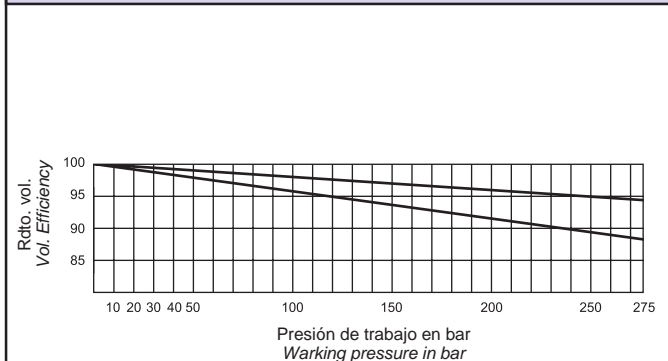
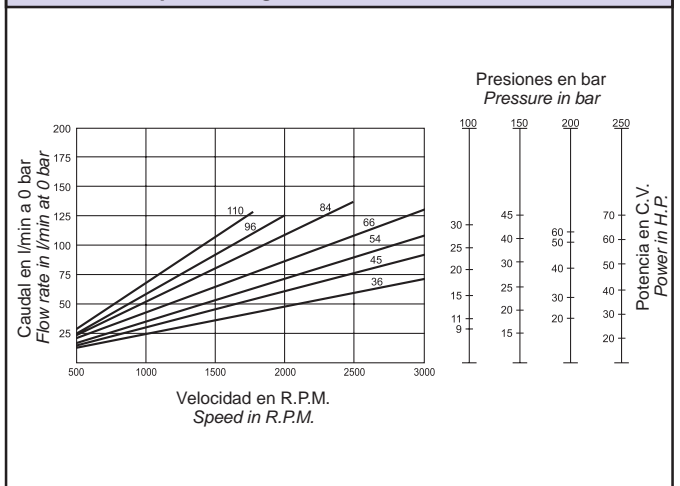

Serie PNC



Datos técnicos hidráulicos Hydraulic technical data

CAUDAL BOMBA PUMP FLOW RATE (L./min.) 1500 r.p.m.	80	100	125	150	175	200	225
CILINDRADA DISPLACEMENT cm ³ /v cc/r	53,6	66,6	83,3	100	116,6	133,3	150
PRESIÓN MÁX. CONTINUA EN CONT. MAX. PRESSURE bar	260		250	225	200	175	
PRESION MAX. INTER. 5 SEG. MAX. INTERMITENT MAX. PRESSURE bar	290		275	250	225	200	
R.P.M. A PRESIÓN CONTINUA RPM. AT CONT. PRESSURE							
R.P.M. MÁXIMAS MAX. R.P.M.		3000		2500	2000	1750	
MINIMAS R.P.M. SEGÚN PRESIÓN	100 bar	400		350			
	175 bar	450		400			
MIN R.P.M. AT GIVEN PRESSURES	250 bar	550		-	-	-	

Tapas anteriores Front covers



Diagrama de rendimientos volumétricos a 1.500 R.P.M. Volumetric efficiencies diagram at 1.500 R.P.M.

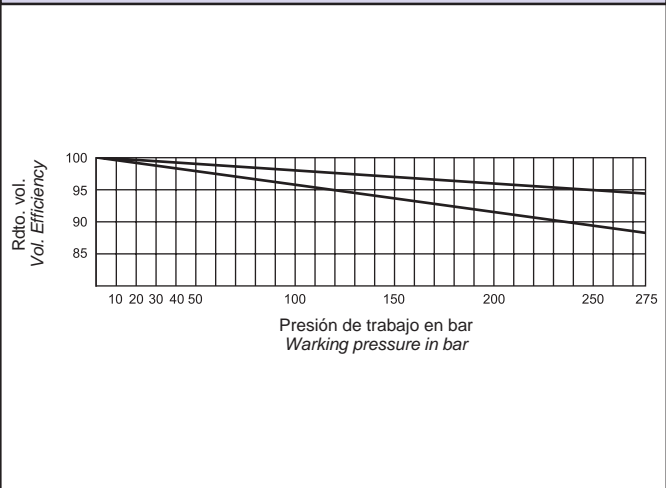

Formas conexión Tomas Port connection form

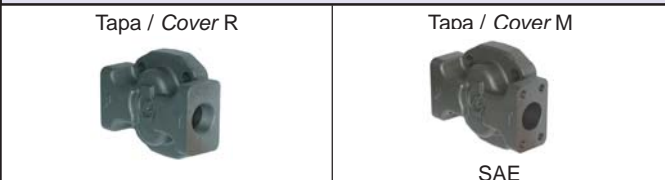

Ejes Shafts



Diagrama de caudales y potencias Flow rate and power diagram



NOTA: Estos diagramas han sido obtenidos con un aceite de 5° E (37cSt) de viscosidad y una temperatura de 50° C
NOTE: These results have been obtained with 5° E (37cSt) viscosity oil and at 50° deg. C

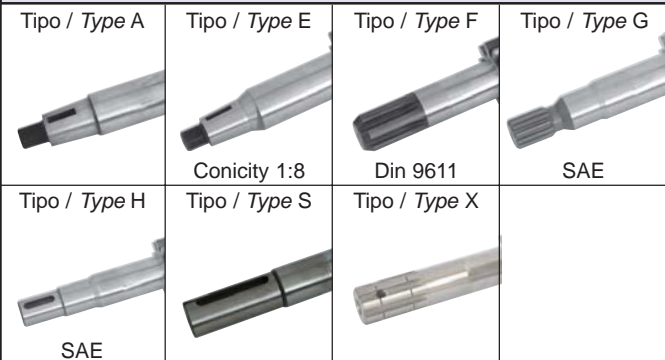
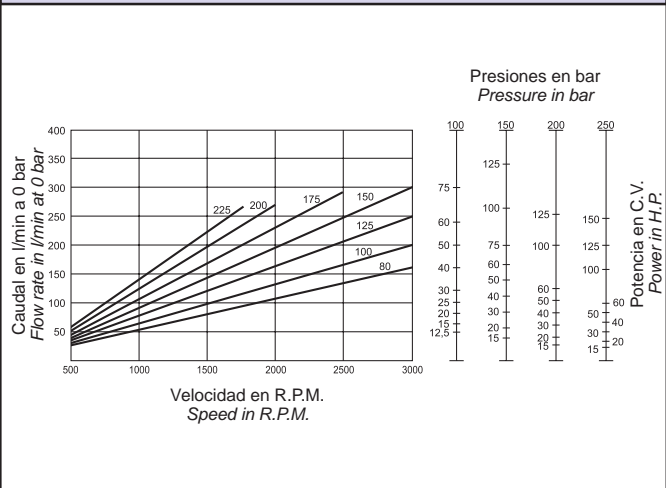

Bombas múltiples / Multiple pump

NOMENCLATURA DE REFERENCIAS

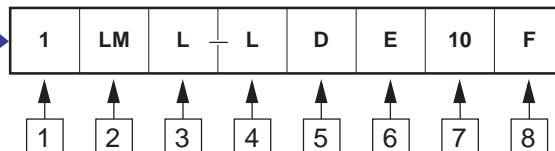

CODING SYSTEMS

1	Tipo <i>Type</i>
1	Sin polea <i>Without pulley</i>

Ver hoja técnica para cada tipo / See technical data for each type

3	Caudal bomba <i>Pump flow rate</i>
Ver hoja técnica individual <i>See technical data</i>	

2	Modelo <i>Model</i>
Combinación bombas aluminio <i>Aluminium pumps combination</i>	
Mismo modelo / Same model	
Tipo <i>Type</i>	Combinación de <i>Combination of</i>
LQ	LO - LO
LM	L - L
PLL	PLA - PLA
PLJ	PLC - PLC
Distinto modelo / Different model	
Tipo <i>Type</i>	Combinación de <i>Combination of</i>
LP	LO - M
LS	L - LO
PLT	PLA - LO
PLD	PLA - L
PLZ	PLC - LO
PLH	PLC - L
PLK	PLC - PLA

4	Caudal bomba <i>Pump flow rate</i>
Ver hoja técnica individual <i>See technical data</i>	

5	Sentido giro <i>Rotation sense</i>
D	Derecha / <i>Clockwise</i>
I	Izquierda / <i>Counterclockwise</i>
R	Reversible / <i>Reversible</i>

6	Forma eje motriz <i>Driving shaft form</i>
Bombas aluminio <i>Aluminium pump</i>	A - B - C - E - F - G - H - J - Q - T
Bombas fundición <i>Cast iron pumps</i>	A - B - C - E - F - G - H - S - X

Ver hoja técnica para cada tipo / See technical data for each type

Combinación bombas fundición <i>Cast iron pumps combination</i>			
Mismo modelo / Same model		Distinto modelo / Different model	
Tipo <i>Type</i>	Combinación de <i>Combination of</i>	Tipo <i>Type</i>	Combinación de <i>Combination of</i>
LQ	LO - LO	PNL	PNA - PNA
PNL	PNA - PNA	PNL	PNA - PNA
PNJ	PNC - PNC	PNJ	PNC - PNC
		PNT	PNA - LO
		PND	PNA - L
		PNZ	PNC - LO
		PNH	PNC - L
		PNK	PNC - PNA

7	Tipo tapas <i>Fixing flange</i>
04 - 06 - 09 - 10 - 13 - 19 - 20 - 21 - 22 - 23 - 29 - 55 - 61	

Ver hoja técnica para cada tipo / See technical data for each type

8	Formas conexión tomas <i>Port connection fom</i>
Bombas aluminio / Aluminium pump	
Bombas fundición / Cast iron pumps	



Válvulas de retención / Check valves

Simple por bola / Ball check valve



VR* R1



Datos técnicos hidráulicos Hydraulic technical data

PRESIÓN MÁXIMA DE TRABAJO
MAX. WORKING PRESSURE

300 bar

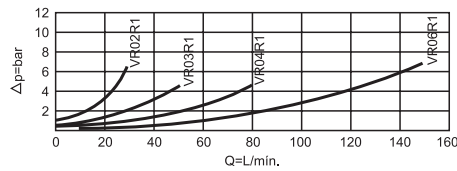

Referencia Reference	\varnothing BSP
VR02R1	1/4"
VR03R1	3/8"
VR04R1	1/2"
VR06R1	3/4"

Simple por cono / Poppet check valve



2VR* R1



Datos técnicos hidráulicos Hydraulic technical data

PRESIÓN MÁXIMA DE TRABAJO
MAX. WORKING PRESSURE

400 bar

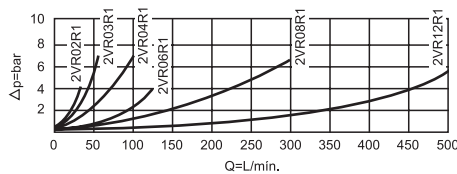

Referencia Reference	\varnothing BSP
2VR02R*	1/4"
2VR03R*	3/8"
2VR04R*	1/2"
2VR06R*	3/4"
2VR08R*	1"
2VR12R*	1 1/2"

Nota: El asterisco de la referencia se sustituirá por un 1 si se desea que la presión de apertura sea de 0,5-1 bar, y por 13 si ha de ser de 5-6 bar.
Note: The reference asterisk will be replaced by number 1 when wanted opening pressure is 0,5-1 bar and by number 13 if 5-6 bar is required.

Montaje por placa / Sub-plate mounting

1VR06P1



Datos técnicos hidráulicos Hydraulic technical data

PRESIÓN MÁXIMA DE TRABAJO
MAX. WORKING PRESSURE

400 bar

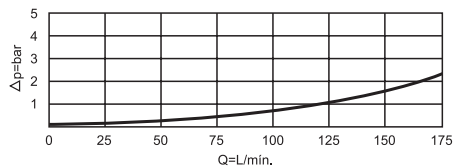

Válvula retención doble pilotada / Double pilot check valve

1VR#* R1



1VRHD* R1

= D Doble
Double

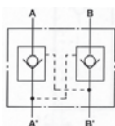

1VRHS* R1

= S Simple
Simple

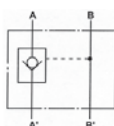

Datos técnicos hidráulicos Hydraulic technical data

PRESIÓN MÁXIMA DE TRABAJO
MAX. WORKING PRESSURE

250 bar

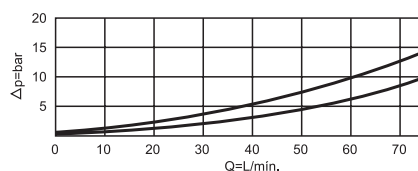

Referencia Reference	\varnothing BSP
03	3/8"
04	1/2"

Cambiar * por 03 o 04 según tomas deseadas
Change * for 03 or 04 depending on ports size



Válvulas de retención / Check valves

Pilotada hidráulicamente / Check valve hydraulic pilot

MONTAJE POR PLACA / SUB-PLATE MOUNTING

1VRHS*R1PA#

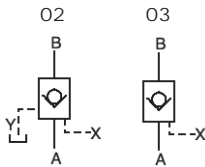

Cambiar # por según drenaje / Change # depending on drain

Datos técnicos hidráulicos Hydraulic technical data	
PRESIÓN MÁXIMA DE TRABAJO MAX. WORKING PRESSURE	350 bar

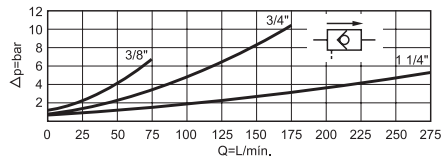
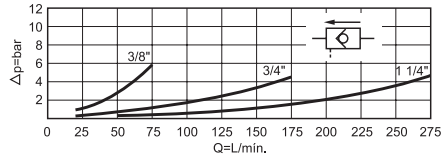

Referencia Reference	Ø BSP
03	1/2"
06	3/4"
10	1 1/4"

Cambiar * por 03,06,10 según tomas
Change * for 03,06,10 depending ports

Pilotada hidráulicamente / Check valve hydraulic pilot CETOP RP69

MONTAJE POR RACORES / SCREWED MOUNTING

1VRHS*P1RA#

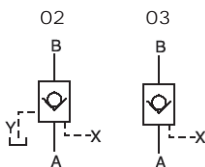

Cambiar # por según drenaje / Change # depending on drain

Datos técnicos hidráulicos Hydraulic technical data	
PRESIÓN MÁXIMA DE TRABAJO MAX. WORKING PRESSURE	350 bar

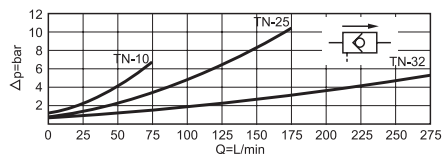
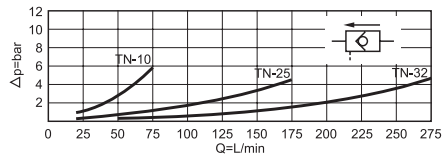

Referencia Reference	Ø BSP
03	1/2"
06	3/4"
10	1 1/4"

Cambiar * por 03,06,10 según tomas
Change * for 03,06,10 depending ports

Montaje por placa / Sub-plate mounting

M9525C00/03R48-50



Tipo Type	Tomas Ports	Voltaje Voltage
9525	3/8"	AC/DC
8728	3/8"	DC
9164	3/8"	CA

Tipo Type	Tomas Ports	Voltaje Voltage
9526	3/8"	DC
9500	3/8"	DC

Tipo Type	Voltaje Voltage
9526	DC
9500	DC

Datos técnicos hidráulicos Hydraulic technical data	
PRESIÓN MÁXIMA DE TRABAJO MAX. WORKING PRESSURE	210 / 250 bar

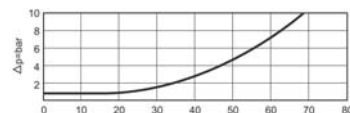

9525 / 9526

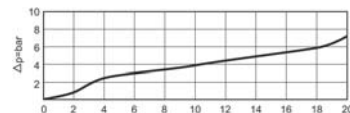

9500

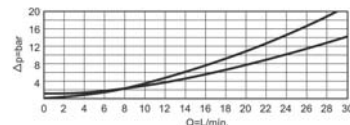

8728 / 9164

Válvulas selectoras / Selector valves

Válvulas selectoras de 6 vías / 6-way selector valve

2025000/*

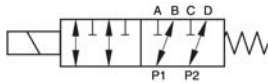

Tomas A, B, C, D, P1 y P2 roscadas a 3/4" -16 UNF-2B - Prof. rosca 17mm
Ports A, B, C, D, P1 and P2 3/4" -16 UNF-2B - Depth 17mm

* = 12/24V CC / 12/24V DC

Datos técnicos hidráulicos / Hydraulic technical data

Presión máxima de trabajo / Max. working pressure	250 bar
Caudal nominal / Nominal flow rate	40 l/min.
Potencia electroimán / Solenoid power	12/24V DC - 40W

Límites de funcionamiento / Operating limits (23cst)

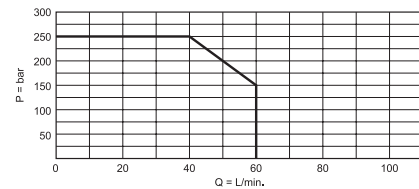

9278000/*

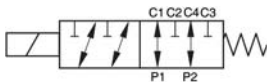

Tomas C1, C2, C3, C4, P1 y P2 roscadas a 3/8" B.S.P. - Prof. rosca 14mm
Ports C1, C2, C3, C4, P1 and P2 3/8" B.S.P. - Depth 14mm

* = 12/24V CC / 12/24V DC

Datos técnicos hidráulicos / Hydraulic technical data

Presión máxima de trabajo / Max. working pressure	250 bar
Caudal nominal / Nominal flow rate	40 l/min.
Potencia electroimán / Solenoid power	12/24V DC - 40W

Límites de funcionamiento / Operating limits (23cst)

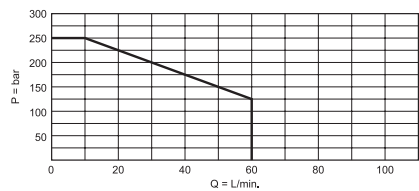

9372000

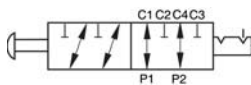

Tomas C1, C2, C3, C4, P1 y P2 roscadas a 3/8" B.S.P. - Prof. rosca 14mm
Ports C1, C2, C3, C4, P1 and P2 3/8" B.S.P. - Depth 14mm

Datos técnicos hidráulicos

Hydraulic technical data

Presión máxima de trabajo Max. working pressure	250 bar
Caudal nominal Nominal flow rate	40 l/min.

Límites de funcionamiento / Operating limits (23cst)

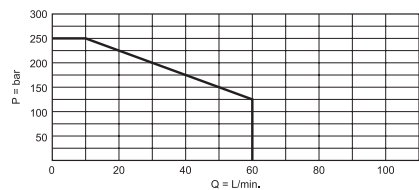

9777000/*

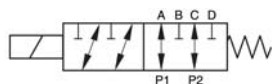

Tomas A, B, C, D, P1 y P2 roscadas a 3/4" 16 UNF-2B - Prof. rosca 18mm.
Ports A, B, C, D, P1 and P2 3/4" 16 UNF-2B - Depth 18mm.

* = 12/24V CC / 12/24V DC

Datos técnicos hidráulicos

Hydraulic technical data

Presión máxima de trabajo / Max. working pressure	250 bar
Caudal nominal / Nominal flow rate	40 l/min.
Potencia electroimán / Solenoid power	12/24V DC - 40W

Límites de funcionamiento / Operating limits (23cst)

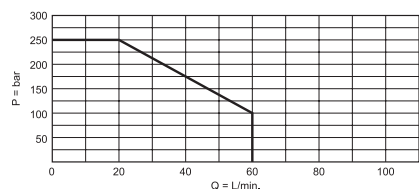

Válvulas selectoras / Selector valves

Válvulas selectoras de 6 vías / 6-way selector valve

9594000/*

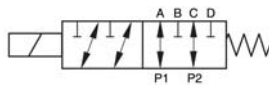

Tomas A, B, C, D, P1 y P2 roscadas a 1/2" B.S.P. - Prof. rosca 15mm
Ports A, B, C, D, P1 and P2 1/2" B.S.P. - Depth 15mm

* = 12/24V CC / 12/24V DC

Datos técnicos hidráulicos / Hydraulic technical data

Presión máxima de trabajo / Max. working pressure	250 bar
Caudal nominal / Nominal flow rate	80 l/min.
Potencia electroimán / Solenoid power	12/24V DC - 60W

Límites de funcionamiento / Operating limits (23cst)

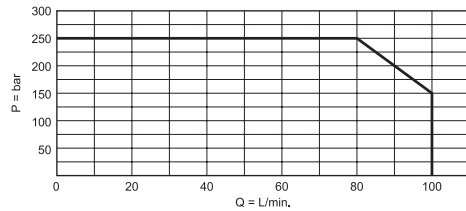

9771000/*

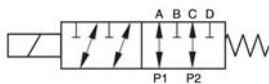

Tomas A, B, C, D, P1 y P2 roscadas a 3/4" 16 UNF-2B - Prof. rosca 18mm.
Ports A, B, C, D, P1 and P2 3/4" 16 UNF-2B - Depth 18mm.

* = 12/24V CC / 12/24V DC

Datos técnicos hidráulicos / Hydraulic technical data

Presión máxima de trabajo / Max. working pressure	250 bar
Caudal nominal / Nominal flow rate	80 l/min.
Potencia electroimán / Solenoid power	12/24V DC - 60W

Límites de funcionamiento / Operating limits (23cst)

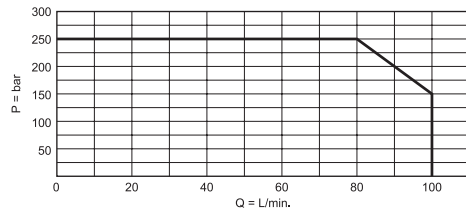

2681000/*

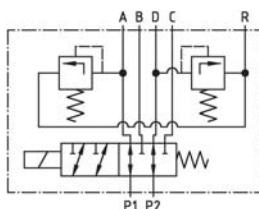
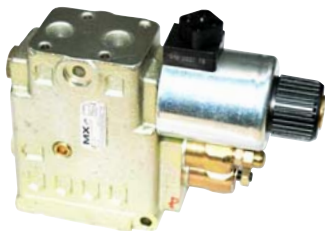

Tomas A, B, C, D, P1, P2 y R, roscadas a M18 x 1,5 - Prof. rosca 14mm.
Ports A, B, C, D, P1, P2 and R, M18 x 1,5 - Depth 14mm.

* = 12/24V CC / 12/24V DC

Datos técnicos hidráulicos / Hydraulic technical data

Presión máxima de trabajo / Max. working pressure	250 bar
Caudal nominal / Nominal flow rate	80 l/min.
Potencia electroimán / Solenoid power	12/24V DC - 60W

Límites de funcionamiento / Operating limits (23cst)

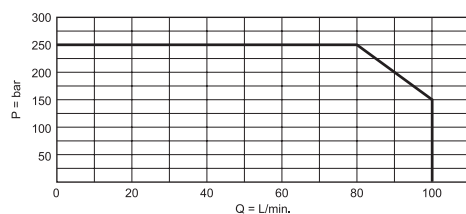

Válvulas selectoras / Selector valves

Válvulas selectoras apilables de 6 vías / Stackable 6-way selector valve

2232000/*

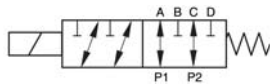

Tomas A, B, C, D, P1 y P2 roscadas a 1/2" B.S.P. - Prof. rosca 15mm
Ports A, B, C, D, P1 and P2 1/2" B.S.P. - Depth 15mm

* = 12/24V CC / 12/24V DC

Datos técnicos hidráulicos / Hydraulic technical data

Presión máxima de trabajo / Max. working pressure	250 bar
Caudal nominal / Nominal flow rate	40 l/min.
Potencia electroimán / Solenoid power	12/24V DC - 40W

Límites de funcionamiento / Operating limits

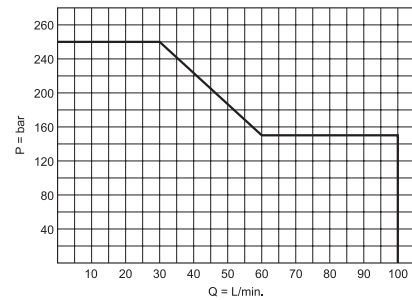

2235000/*

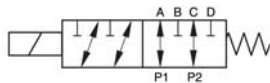

Tomas A, B, C, D, P1 y P2 roscadas a 1/2" B.S.P. - Prof. rosca 15mm
Ports A, B, C, D, P1 and P2 1/2" B.S.P. - Depth 15mm

* = 12/24V CC / 12/24V DC

Datos técnicos hidráulicos / Hydraulic technical data

Presión máxima de trabajo / Max. working pressure	250 bar
Caudal nominal / Nominal flow rate	80 l/min.
Potencia electroimán / Solenoid power	12/24V DC - 40W

Límites de funcionamiento / Operating limits

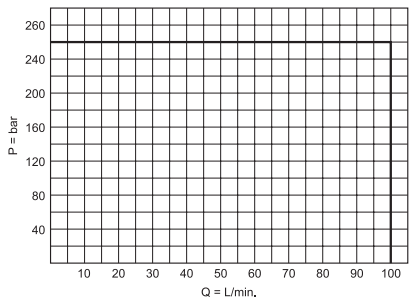

Válvulas selectoras de 8 vías / 8-way selector valve

9373000/*

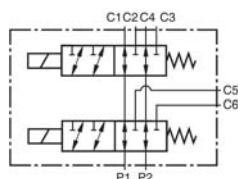

Tomas C1, C2, C3, C4, C5, C6, P1 y P2 - roscadas a 3/8" B.S.P.
Prof. rosca 15mm
Ports C1, C2, C3, C4, C5, C6, P1 and P2 - 3/8" B.S.P.
Depth 15mm

* = 12/24V CC / 12/24V DC

Datos técnicos hidráulicos / Hydraulic technical data

Presión máxima de trabajo / Max. working pressure	250 bar
Caudal nominal / Nominal flow rate	40 l/min.
Potencia electroimán / Solenoid power	12/24V DC - 40W
Tipo conector / Connection type	Hirschman ISO 4400

Límites de funcionamiento / Operating limits (23cst)

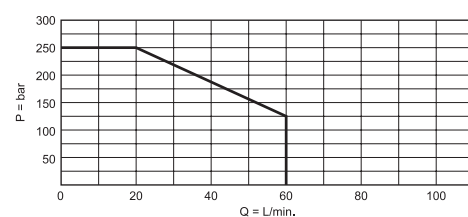



Reguladores de presión / Pressure control valves

Válvulas reguladoras de presión / Pressure control valves

3RLP03R▲#

3/8" BSP
MONTAJE POR PANEL / PANEL MOUNTING

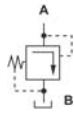

Cambiar ▲ por regulación (1, 2, 3, 4)
Change ▲ depending on adjusting type (1, 2, 3, 4)
Cambiar # por taraje requerido / Change # depending on setting range

Datos técnicos hidráulicos / Hydraulic technical data	
Presión máxima de trabajo / Max. working pressure	300 bar
Caudal nominal / Nominal flow rate	40 l/min.

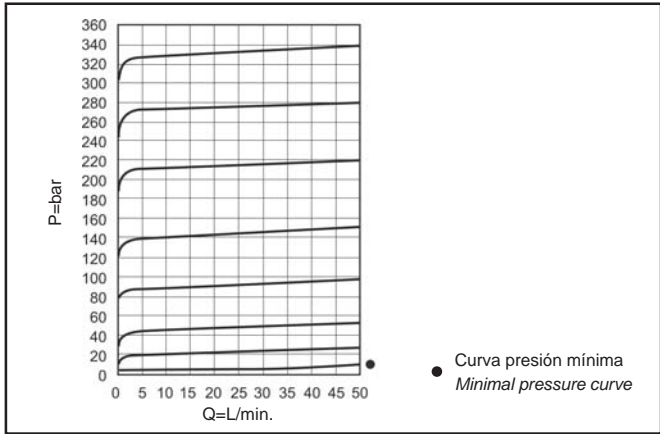

3RL03R▲# / 3RS03R▲# / 3RD03R▲#

3/8" BSP
MONTAJE POR RACORES / THREADED PORTS



3RL
Reguladores
de presión
Pressure
control valve

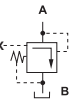

3RS
Válvula
secuencia
Sequence
valve

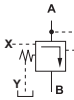

3RD
Válvula des.
en vacío
Unloading
valve

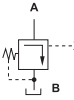

Cambiar ▲ por regulación / Change ▲ depending on adjusting type
Cambiar # por taraje requerido / Change # depending on setting range

Datos técnicos hidráulicos / Hydraulic technical data	
Presión máxima de trabajo / Max. working pressure	350 bar
Caudal nominal / Nominal flow rate	40 l/min.

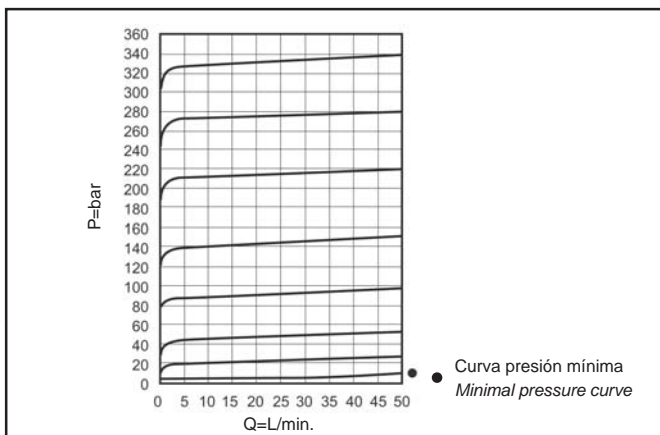

3RL03P▲# / 3RS03P▲# / 3RD03P▲#

TN10
MONTAJE POR PLACA / SUB-PLATE MOUNTING



3RL
Reguladores
de presión
Pressure
control valve



3RS
Válvula
secuencia
Sequence
valve



3RD
Válvula des.
en vacío
Unloading
valve



Cambiar ▲ por regulación (1, 2, 3, 4)
Change ▲ depending on adjusting type (1, 2, 3, 4)
Cambiar # por taraje requerido / Change # depending on setting range

Datos técnicos hidráulicos / Hydraulic technical data	
Presión máxima de trabajo / Max. working pressure	350 bar
Caudal nominal / Nominal flow rate	40 l/min.

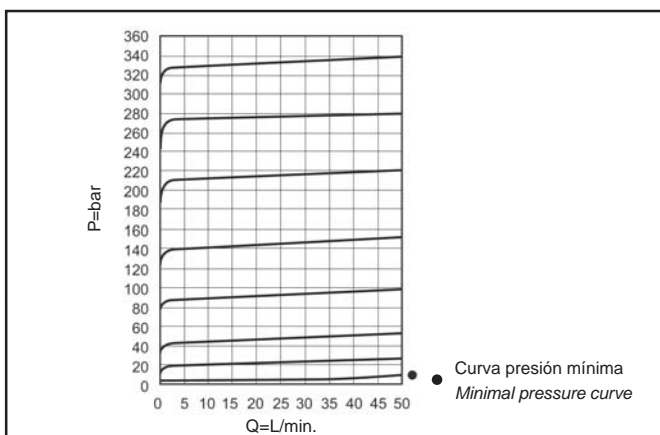



Reguladores de presión / Pressure control valves

Válvulas reguladoras de presión / Pressure control valves

3RL06R▲# / 3RS06R▲# / 3RD06R▲#

3/4" BSP
MONTAJE POR RACORES / THREADED PORTS

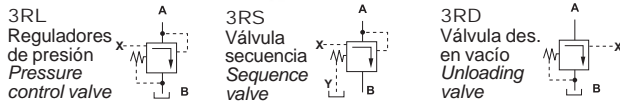

Cambiar ▲ por regulación (1, 2, 3, 4)
Change ▲ depending on adjusting type (1, 2, 3, 4)
Cambiar # por taraje requerido / Change # depending on setting range

Datos técnicos hidráulicos / Hydraulic technical data

Presión máxima de trabajo / Max. working pressure	350 bar
Caudal nominal / Nominal flow rate	120 l/min.

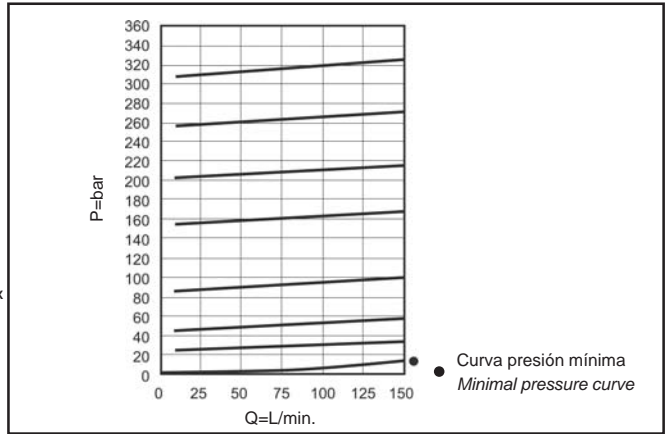

3RL06P▲# / 3RS06P▲# / 3RD06P▲#

TN25
MONTAJE POR PLACA / SUB-PLATE MOUNTING



Cambiar ▲ por regulación (1, 2, 3, 4)
Change ▲ depending on adjusting type (1, 2, 3, 4)
Cambiar # por taraje requerido / Change # depending on setting range

Datos técnicos hidráulicos / Hydraulic technical data

Presión máxima de trabajo / Max. working pressure	350 bar
Caudal nominal / Nominal flow rate	120 l/min.

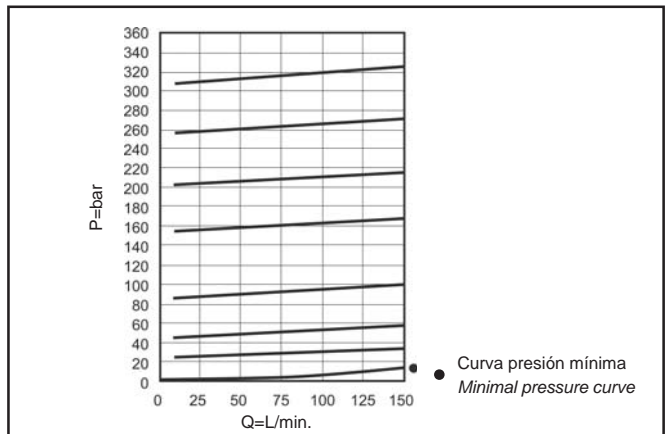

3RL12B▲# / 3RS12B▲# / 3RD12B▲#

1 1/2 BSP
MONTAJE POR BRIDA / FLANGE MOUNTING

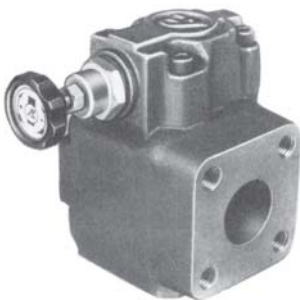

Cambiar ▲ por regulación (1, 2, 3, 4)
Change ▲ depending on adjusting type (1, 2, 3, 4)
Cambiar # por taraje requerido / Change # depending on setting range

Datos técnicos hidráulicos / Hydraulic technical data

Presión máxima de trabajo / Max. working pressure	350 bar
Caudal nominal / Nominal flow rate	250 l/min.

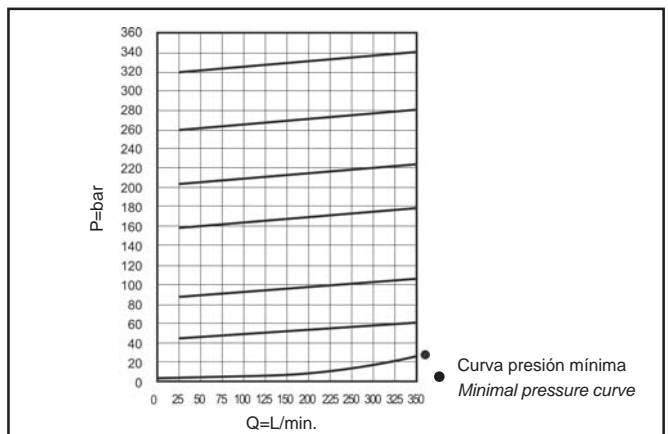



Reguladores de presión / Pressure control valves

Válvulas reguladoras de presión / Pressure control valves

3RL12P▲# / 3RS12P▲# / 3RD12P▲#

TN32
MONTAJE POR PLACA / SUB-PLATE MOUNTING



3RL
Reguladores
de presión
Pressure
control valve

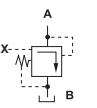

3RS
Válvula
secuencia
Sequence
valve

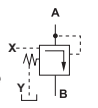

3RD
Válvula des.
en vacío
Unloading
valve

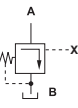

Cambiar ▲ por regulación (1, 2, 3, 4)
Change ▲ depending on adjusting type (1, 2, 3, 4)
Cambiar # por taraje requerido / Change # depending on setting range

Datos técnicos hidráulicos / Hydraulic technical data

Presión máxima de trabajo / Max. working pressure	350 bar
Caudal nominal / Nominal flow rate	250 l/min.

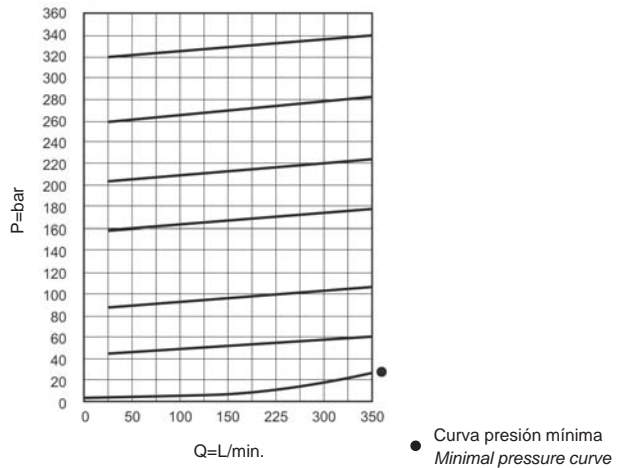

1RLD◆R2#/#

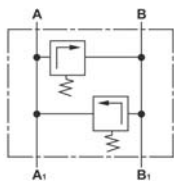

Taraje = Presiones
Settings = Pressure

B	= 5-80 bars
D	= 85-175 bars
F	= 180-250 bars

Sustituir por gama de taraje B-D-F que desee.
Replace by B-D-F according to setting pressure required.
◆ 03 toma / port 3/8" BSP
04 toma / port 1/2" BSP

Datos técnicos hidráulicos / Hydraulic technical data

Presión máxima de trabajo / Max. working pressure	250 bar
Caudal nominal / Nominal flow rate	40 l/min.

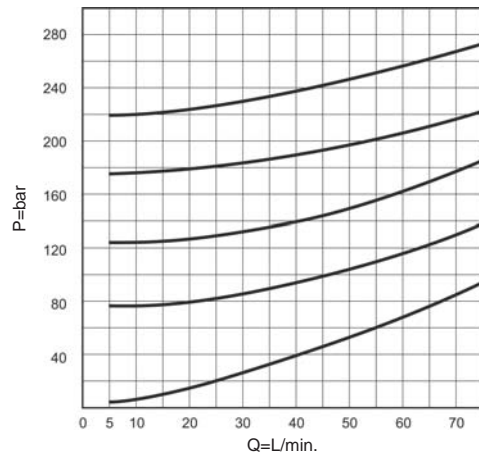

▲ Formas de regulación / Adjusting type

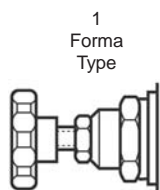

Volante
Knob

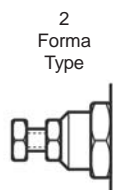

Tuerca y Contratuercas
Nut & lock nut

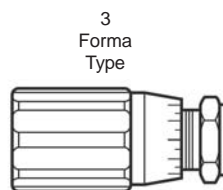

Puño
Long knob

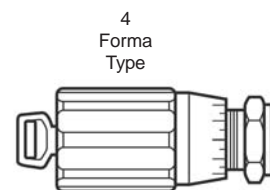

Puño con llave
Long knob with key



Reguladores de presión / Pressure control valves

Válvulas limitadoras / Relief valves

SGRA◆/G#



Tipo Type	Presión Pressure	Caudal Fw. rate
SGRA03/G11	5-80	40
SGRA03/G12	85-175	
SGRA03/G13	180-250	
SGRA03/G14	255-350	

Tipo Type	Presión Pressure	Caudal Fw. rate
SGRA06/G11	5-80	100
SGRA06/G12	85-175	
SGRA06/G13	180-250	
SGRA06/G14	255-350	

03 toma / port 3/8" BSP - 40l.
06 toma / port 1/2" BSP - 100l.

Datos técnicos hidráulicos / Hydraulic technical data

Presión máxima de trabajo / Max. working pressure	350 bar
Caudal nominal / Nominal flow rate	40/100 l/min.

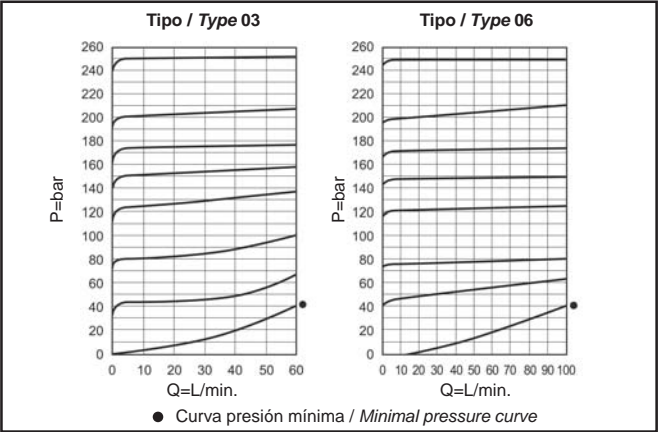

SGRP◆/G#



Tipo Type	Presión Pressure	Caudal Fw. rate
SGRP03/G11	5-80	40
SGRP03/G12	85-175	
SGRP03/G13	180-250	
SGRP03/G14	255-350	

Tipo Type	Presión Pressure	Caudal Fw. rate
SGRP06/G11	5-80	100
SGRP06/G12	85-175	
SGRP06/G13	180-250	
SGRP06/G14	255-350	

03 toma / port 3/8" BSP - 40l. # 06 toma / port 3/4" BSP - 100l.

▲ Formas de regulación / Adjusting type

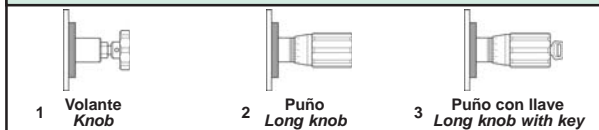

Datos técnicos hidráulicos / Hydraulic technical data

Presión máxima de trabajo / Max. working pressure	350 bar
Caudal nominal / Nominal flow rate	40/100 l/min.

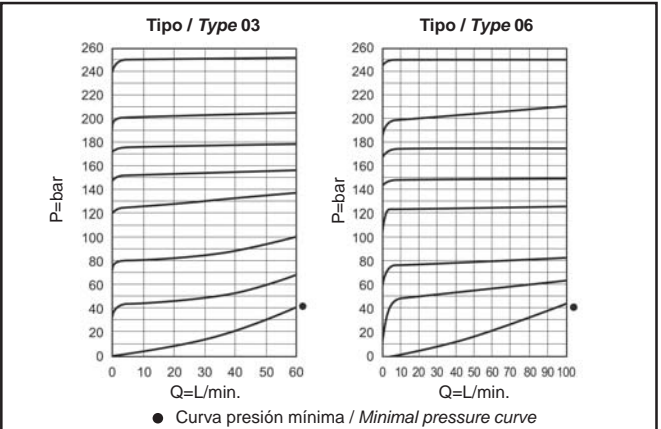

SGRD03/G#

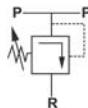

Tipo Type	Presión Pressure	Caudal Fw. rate
SGRD03/G11	5-80	40
SGRD03/G12	85-175	
SGRD03/G13	180-250	

03 toma / port 3/8" BSP - 40l.

Datos técnicos hidráulicos / Hydraulic technical data

Presión máxima de trabajo / Max. working pressure	250 bar
Caudal nominal / Nominal flow rate	40 l/min.

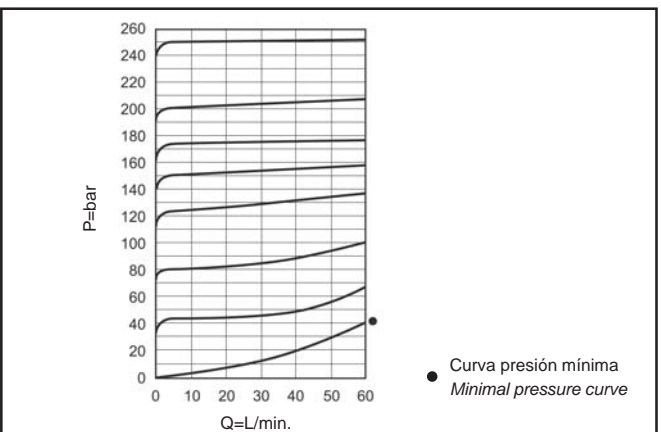





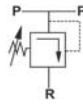

Reguladores de presión / Pressure control valves

Válvulas limitadoras / Relief valves

SGRDP03-▲/G2#



Tipo / Type	# Presión / Pressure
SGRDP03 - ▲ / G21	5 - 80
SGRDP03 - ▲ / G22	85 - 175
SGRDP03 - ▲ / G23	180 - 250
SGRDP03 - ▲ / G24	255 - 350

▲ Formas de regulación / Adjustment type			
 Forma 1 Volante Knob	 Forma 2 Tuerca y Contratuera Nut & lock nut	 Forma 3 Puño Long knob	 Forma 4 Puño con llave Long knob with key

Datos técnicos hidráulicos / Hydraulic technical data	
Presión máxima de trabajo / Max. working pressure	350 bar
Caudal nominal / Nominal flow rate	40 l/min.

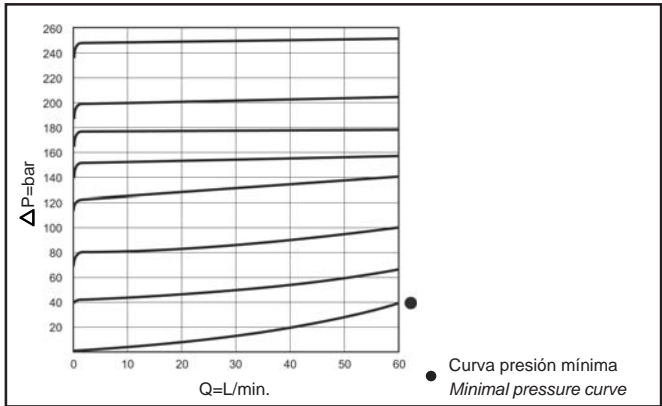

Válvulas limitadoras unidireccional / Unidirectional relief valves

RA03R▲#

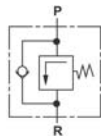

Tomas / Ports 3/8" BSP



- ▲ Sustituir por forma de regulación que desee (2 o 5) .
Replace by (2 or 5) according to adjusting type required.
- # Sustituir B, D o F según taraje requerido.
Replace B, D o F depending setting range.

Datos técnicos hidráulicos / Hydraulic technical data	
Presión máxima de trabajo / Max. working pressure	250 bar
Caudal nominal / Nominal flow rate	40 l/min.

#	Presiones Pressure
B	5 - 80
D	85 - 175
F	180 - 250

▲ Formas de regulación / Adjusting type	
 Tipo / Type 2	 Tipo / Type 5

RA06R2#*

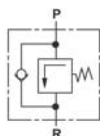

#	Presiones Pressure
B	5 - 80
D	85 - 175
F	180 - 250

* Gama de Presiones P → R
Pressure range
1 = 1 bar
3 = 5-6 bar

Datos técnicos hidráulicos / Hydraulic technical data	
Presión máxima de trabajo / Max. working pressure	250 bar
Caudal nominal / Nominal flow rate	100 l/min.

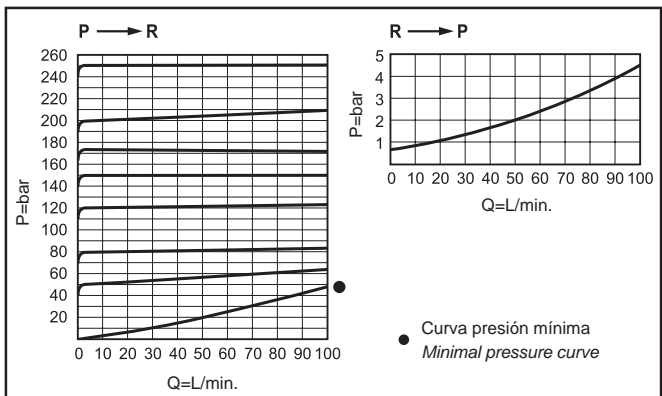



Válvulas limitadoras empotrables / Relief valves

Datos técnicos hidráulicos Hydraulic technical data

Presión máxima de trabajo Max. working pressure	350 bar
Caudal nominal Nominal flow rate	20 l/min

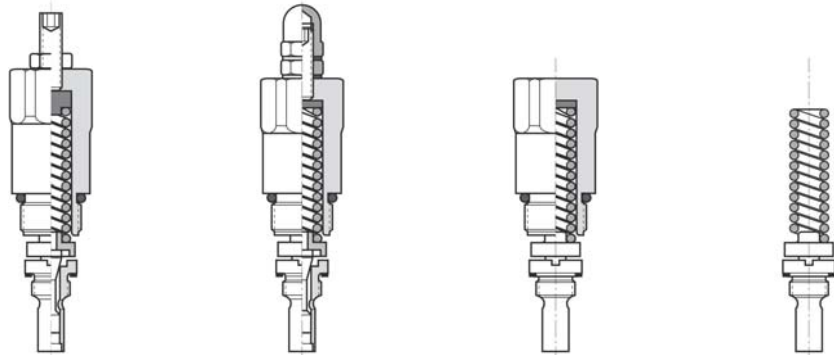

Taraje / Setting	Regulable por tornillo / Screw adjustment		Fija / Fixed	
5-80 bar	8653051	8653011	8653001	8653007
85-175 bar	8653052	8653012	8653002	8653006
180-250 bar	8653053	8653013	8653003	8653005
255-350 bar	8653054	8653014	8653004	8653008

Datos técnicos hidráulicos Hydraulic technical data

Presión máxima de trabajo Max. working pressure	350 bar
Caudal nominal Nominal flow rate	40 l/min

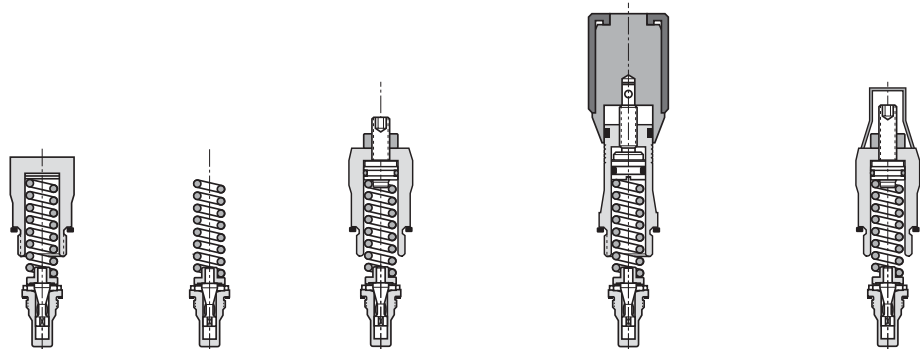

Taraje Setting	Fija Fixed	Sin tapón Without plug	Regulable por tornillo Screw adjustment	Regulable por volante Knob adjustment		Fija precintada Lock wired
				sin cerradura without lock	con cerradura with lock	
5-80 bar	2249001	2249005	2249011	2249021	2249031	2249041
85-175 bar	2249002	2249006	2249012	2249022	2249032	2249042
180-250 bar	2249003	2249007	2249013	2249023	2249033	2249043
255-350 bar	2249004	2249008	2249014	2249024	2249034	2249044

Datos técnicos hidráulicos Hydraulic technical data

Presión máxima de trabajo Max. working pressure	350 bar
Caudal nominal Nominal flow rate	100 l/min

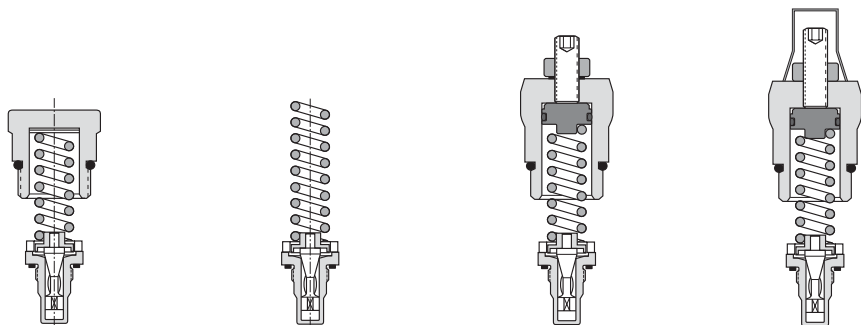

Taraje Setting	Fija Fixed	Sin tapón Without plug	Regulable por tornillo Screw adjustment	Regulable precintada Seal adjustment
5-80 bar	2264001	2264005	2264011	2264041
85-175 bar	2264002	2264006	2264012	2264042
180-250 bar	2264003	2264007	2264013	2264043



Reguladores de presión / Pressure control valves

Válvulas reductoras de presión / Pressure reducing valves

4RR02R-▲/P#



Datos técnicos hidráulicos / Hydraulic technical data

Presión máxima de trabajo / Max. working pressure	250 bar
Caudal nominal / Nominal flow rate	40 l/min.

▲ Formas de regulación / Adjustment type

Forma 2	Forma 3
Tuerca y Contratuera Nut & lock nut	Punyo Long knob

Tipo / Type	#	Presiones / Pressure
4RR02R▲ /P	A	3-30
4RR02R▲ /P	B	35-80
4RR02R▲ /P	D	85-175
4RR02R▲ /P	F	180-250

MONTAJE POR PLACA / SUB-PLATE MOUNTING

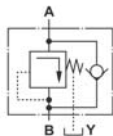

3RR *P▲#

Datos técnicos hidráulicos / Hydraulic technical data

Presión máxima de trabajo / Max. working pressure	350 bar
Caudal nominal / Nominal flow rate	40/120/250 l/min.

#	Presiones / Pressure
B	5 - 80
D	85 - 175
F	180 - 250

* Tamaño / Size 03 - TN10 40l.
06 - TN25 120l.
12 - TN32 250l.

▲ Formas de regulación / Adjustment type

Forma 1	Forma 2
Volante Knob	Tuerca y contratuera Nut & lock nut

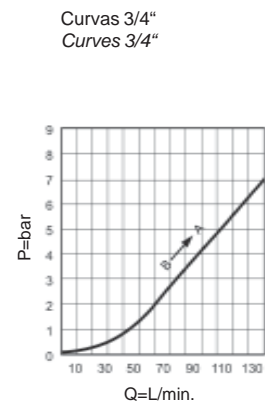
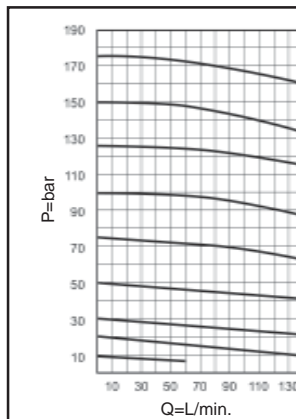

MONTAJE POR RACORES / THREADED PORTS

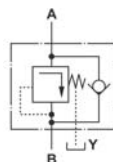

3RR *R▲#

Datos técnicos hidráulicos / Hydraulic technical data

Presión máxima de trabajo / Max. working pressure	350 bar
Caudal nominal / Nominal flow rate	40/120/250 l/min.

#	Presiones / Pressure
B	5 - 80
D	85 - 175
F	180 - 250

* Tamaño / Size 03 - 3/8" 40l.
06 - 3/4" 120l.
12 - 1/2" 250l.

▲ Formas de regulación / Adjustment type

Forma 1	Forma 2
Volante Knob	Tuerca y contratuera Nut & lock nut

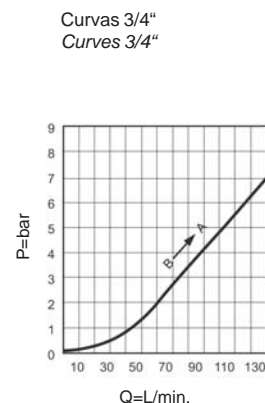
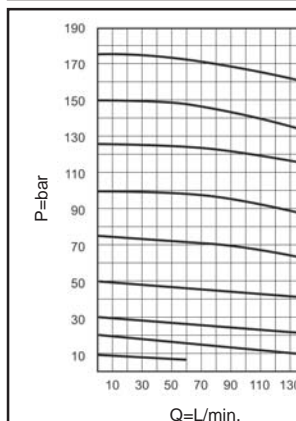



Reguladores de presión / Pressure control valves

Válvulas de secuencia / Sequence valve

RA03R#-S

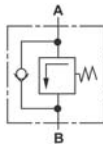

Datos técnicos hidráulicos / Hydraulic technical data

Presión máxima de trabajo / Max. working pressure	250 bar
Caudal nominal / Nominal flow rate	40 l/min.

Tipo Type	Presiones Pressure	Tomas Ports
RA03R2B-S	5-80	3/8" BSP
RA03R2D-S	85-175	
RA03R2F-S	180-250	

MONTAJE POR PLACA / SUB-PLATE MOUNTING



2RS▲P

Tipo Type	Presiones Pressure	Tamaño = Caudal Size = Flow rate
2RS ▲ P1B	5-20	TN-10 / NG-10 = 40 TN-25 / NG-25 = 120 TN-32 / NG-32 = 250
2RS ▲ P1D	25-70	
2RS ▲ P1E	75-140	
2RS ▲ P1F	145-250	

▲ 03 = TN-10 / NG-10
06 = TN-25 / NG-25
12 = TN-32 / NG-32

Datos técnicos hidráulicos / Hydraulic technical data

Presión máxima de trabajo / Max. working pressure	250 bar
Caudal nominal / Nominal flow rate	40/120/250 l/min.

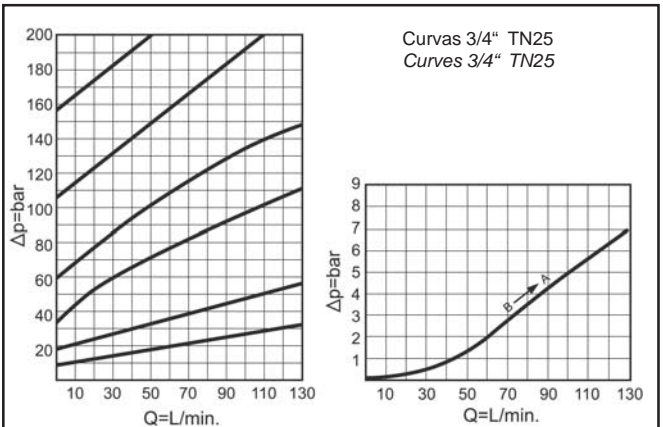

MONTAJE POR PLACA / SUB-PLATE MOUNTING



2RS▲R

Tipo Type	Presiones Pressure	Tomas = Caudal Ports = Flow rate
2RS ▲ R1B	5-20	3/8" = 40 3/4" = 120 1 1/2" = 250
2RS ▲ R1D	25-70	
2RS ▲ R1E	75-140	
2RS ▲ R1F	145-250	

▲ 03 = 3/8"
06 = 3/4"
12 = 1 1/2"

Datos técnicos hidráulicos / Hydraulic technical data

Presión máxima de trabajo / Max. working pressure	250 bar
Caudal nominal / Nominal flow rate	40/120/250 l/min.

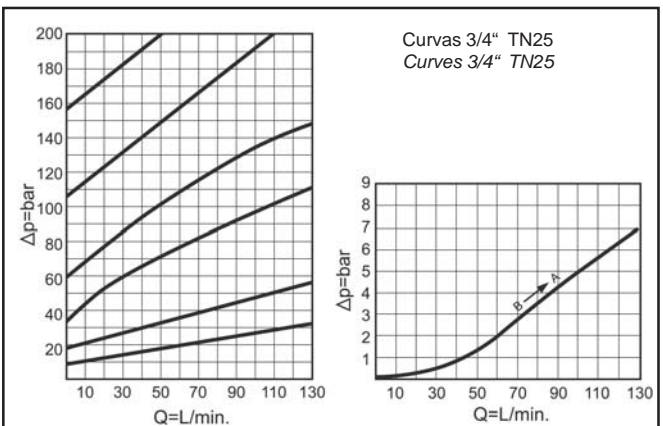



Válvulas de frenado / Overcentre valve

DRENAJE INTERNO / INTERNAL DRAIN
Tomas / Ports 1/2" BSP
Aplicaciones centro abierto / Open centre application



2VDF04R * - ●

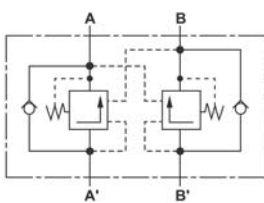

2VSF04R * - ●

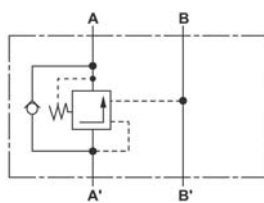

D = Doble / Double
S = Simple / Single

Válvula de frenado Overcentre valve	Tipo regulación / Adjustment		Presiones Pressure
	Fija/Pre-set type	Contratuercal/Screw type	
2VDF04R * - ▲	1	11	5-80
2VDFS04R * - ▲	2	12	85-175
	3	13	180-250
	4	14	255-350

* El asterisco de la referencia se sustituirá por el tipo de regulación y el taraje que se desee.
The asterisk of the part number shall be replaced by the adjustment type and the pressure setting required.

● Rel. de pilotaje 2,5
Pilot ratios 7

Datos técnicos hidráulicos / Hydraulic technical data

Presión máxima de trabajo / Max. working pressure	350 bar
Caudal nominal / Nominal flow rate	80 l/min.

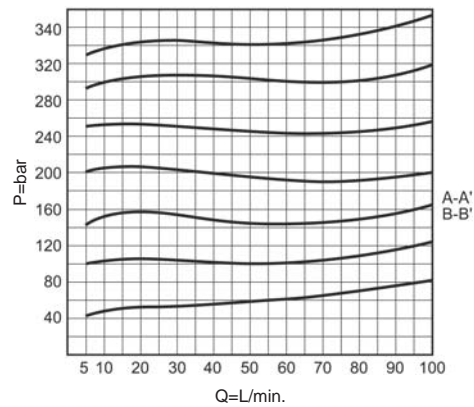
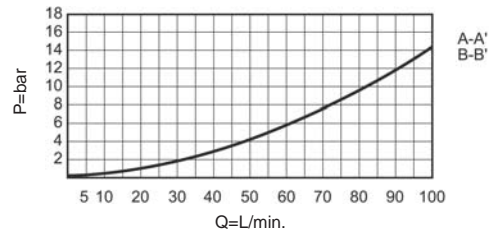

2VDF - 2VSF

DRENAJE EXTERNO / EXTERNAL DRAIN
Tomas / Ports 1/2" BSP
Aplicaciones centro cerrado / Closed centre application



2VDFS04R * - ▲

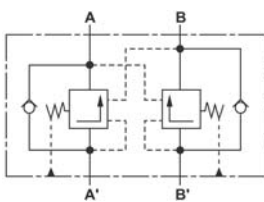

2VSFS04R * - ▲

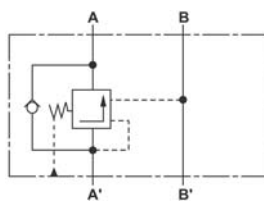

D = Doble / Double
S = Simple / Single

Válvula de frenado Overcentre valve	Tipo regulación / Adjustment		Presiones Pressure
	Fija/Pre-set type	Contratuercal/Screw type	
2VDFS04R * - ▲	1	11	5-80
2VSFS04R * - ▲	2	12	85-175
	3	13	180-250
	4	14	255-350

* El asterisco de la referencia se sustituirá por el tipo de regulación y el taraje que se desee.
The asterisk of the part number shall be replaced by the adjustment type and the pressure setting required.

● Rel. de pilotaje 2,5
Pilot ratios 7

Datos técnicos hidráulicos / Hydraulic technical data

Presión máxima de trabajo / Max. working pressure	350 bar
Caudal nominal / Nominal flow rate	80 l/min.

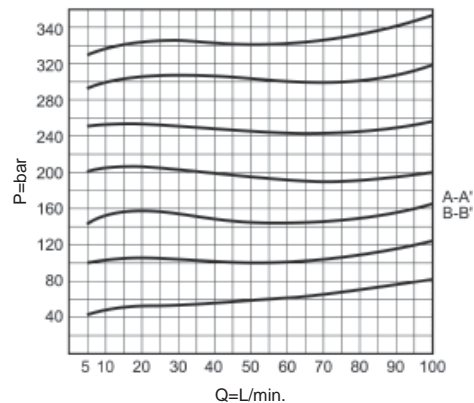
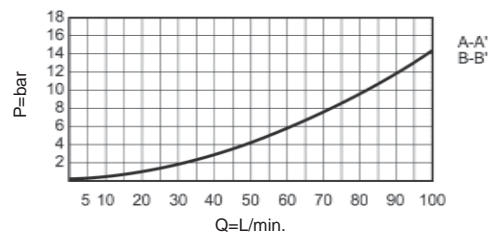

2VDFS - 2VSFS



Reguladores de caudal / Flow control valves

Regulador de 2 vías / 2-way flow control valve

1VCR*RA▶

MONTAJE POR RACORES / IN-LINE MOUNTING



Datos técnicos hidráulicos / Hydraulic technical data

Presión máxima de trabajo / Max. working pressure	250 bar
Caudal nominal / Nominal flow rate	TN-6 / NG-6 35 l/min.
Caudal nominal / Nominal flow rate	TN-10 / NG-10 70 l/min.

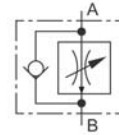

Cambiar * por / Change * for
02 → 3/8" / * = 03 → 1/2"

Cambiar ▶ por tipo regulación / Change ▶ depending on adjusting type

1VCRE*RA▶

MONTAJE POR PLACA / SUB-PLATE MOUNTING



Datos técnicos hidráulicos / Hydraulic technical data

Presión máxima de trabajo / Max. working pressure	250 bar
Caudal nominal / Nominal flow rate	TN-6 / NG-6 35 l/min.
Caudal nominal / Nominal flow rate	TN-10 / NG-10 70 l/min.

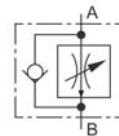

Cambiar * por / Change * for
02 → 3/8" / * = 03 → 1/2"

Cambiar ▶ por tipo regulación / Change ▶ depending on adjusting type

TN-6 / NG-6

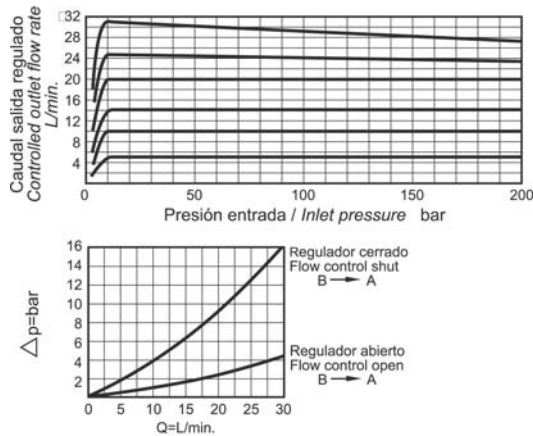

TN-10 / NG-10

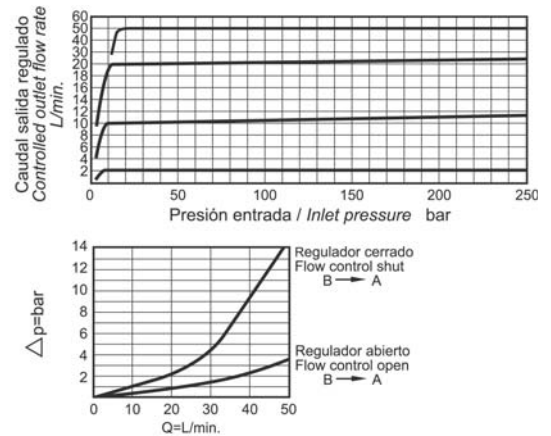

▲ Formas de regulación / Adjusting type

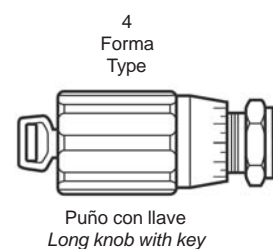
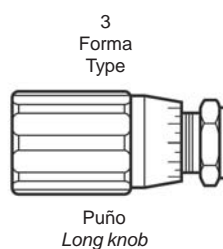
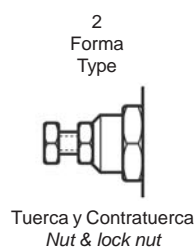
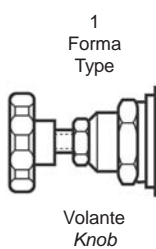

Sustituir ▲ por el numero de forma deseada / Replace ▲ by adjusting type number needed



Reguladores de caudal / Flow control valves

Regulador de 3 vías / 3-way flow control valve

MONTAJE POR RACORES / IN-LINE MOUNTING

1VCR*RA▶



Datos técnicos hidráulicos / Hydraulic technical data	
Presión máxima de trabajo / Max. working pressure	250 bar
Caudal nominal / Nominal flow rate	TN-6 / NG-6 35 l/min.
Caudal nominal / Nominal flow rate	TN-10 / NG-10 70 l/min.

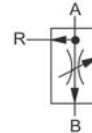

Cambiar * por / Change * for
02 → 3/8" / * = 03 → 1/2"

Cambiar ▲ por tipo regulación / Change ▲ depending on adjusting type

MONTAJE POR PLACA / SUB-PLATE MOUNTING

1VCRE*RA▶



Datos técnicos hidráulicos / Hydraulic technical data	
Presión máxima de trabajo / Max. working pressure	250 bar
Caudal nominal / Nominal flow rate	TN-6 / NG-6 35 l/min.
Caudal nominal / Nominal flow rate	TN-10 / NG-10 70 l/min.

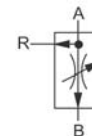

Cambiar * por / Change * for
02 → 3/8" / * = 03 → 1/2"

Cambiar ▲ por tipo regulación / Change ▲ depending on adjusting type

TN-6 / NG-6

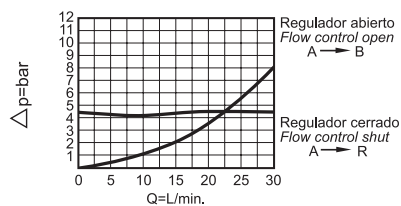
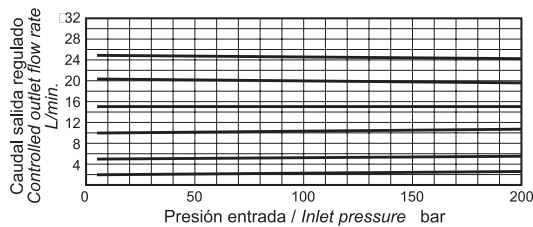

TN-10 / NG-10

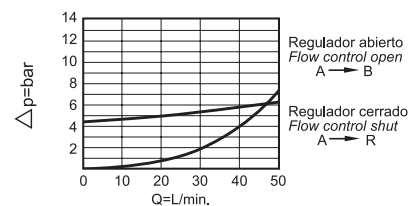
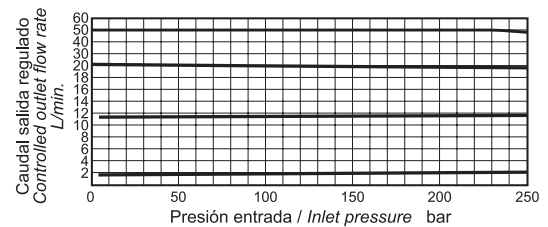

▲ Formas de regulación / Adjusting type

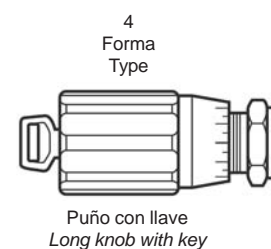
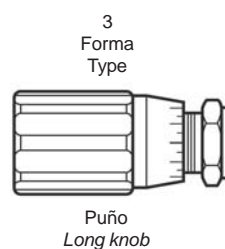
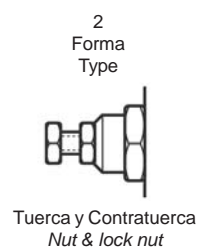
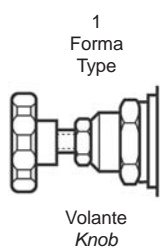

Sustituir ▲ por el número de forma deseada / Replace ▲ by adjusting type number needed



Reguladores de caudal / Flow control valves

Repartidor de caudal / Flow divider

Tomas / Ports 3/8" BSP

RC04R*

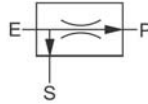

Datos técnicos hidráulicos / Hydraulic technical data

Presión máxima de trabajo / Max. working pressure	250 bar
Caudal nominal / Nominal flow rate	60 l/min.

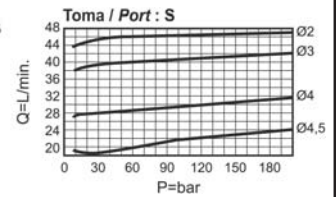
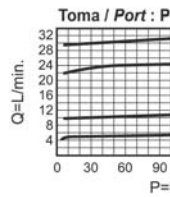
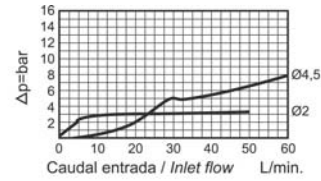

Caudal prioritario en P / Flow priority at P (l/min.)

* = 4,5 - 6,6 - 10,6 - 13,5 - 21,5 - 23,5 - 27,5

Divisor de caudal / Flow divider

Tomas / Ports 3/8" BSP

DC03R*

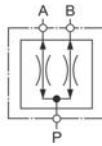

Datos técnicos hidráulicos / Hydraulic technical data

Presión máxima de trabajo / Max. working pressure	250 bar
---	---------

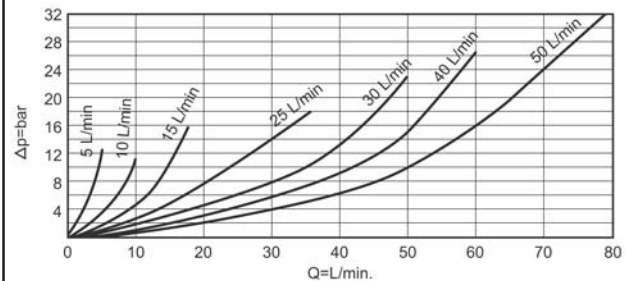

Canviar * por Change * por	5	10	15	25	30	40	50
Caudal entrada Inlet flow (l/min)	1,5-5	4-10	5-15	10-25	20-30	25-40	30-50

Estrangulador con válvula antiretorno / Throttle with check valve

EG★RVR



Datos técnicos hidráulicos / Hydraulic technical data

Presión máxima de trabajo / Max. working pressure	350 bar
---	---------

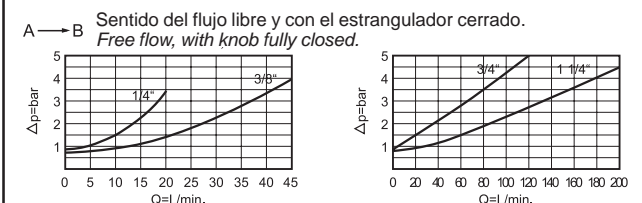
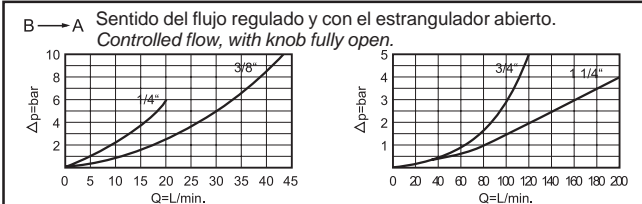

Cambiar ★ por tamaño deseado (02, 03, 06, 10)
Change ★ depending on required size (02, 03, 06, 10)

Tipo Type	Caudal Flow rate	Tomas Ports	Tipo Type	Caudal Flow rate	Tomas Ports
1EG02RVR	20	1/4" BSP	EG06RVR	120	3/4" BSP
1EG03RVR	45	3/8" BSP	EG10RVR	200	1 1/4" BSP



Reguladores de caudal / Flow control valves

Válvulas de frenado / Braking valve

Tomas / Ports 3/8" BSP



Datos técnicos hidráulicos / Hydraulic technical data

Presión máxima de trabajo / Max. working pressure	250 bar
---	---------

Caudal nominal / Nominal flow rate ±10% a 100 bar

* = 10 - 14 - 21 - 25 - 29 - 34 - 37 - 45 - 55

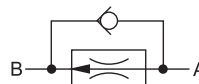

VF03R*

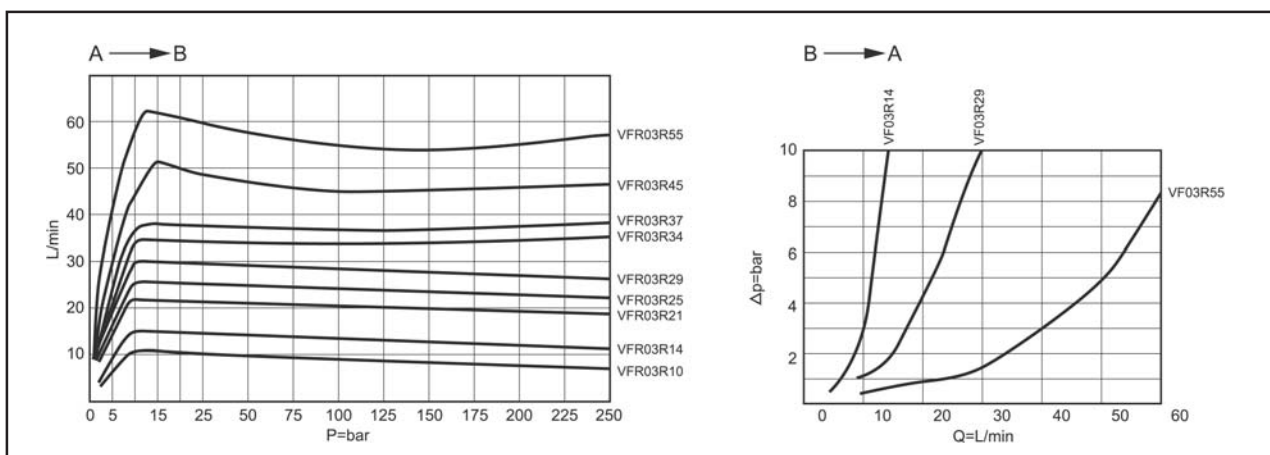

Tomas / Ports 1/4" BSP



Datos técnicos hidráulicos / Hydraulic technical data

Presión máxima de trabajo / Max. working pressure	210 bar
---	---------

Caudal nominal / Nominal flow rate ±10% a 100 bar

* = 1 - 2 - 3 - 4 - 5 - 6 - 7 - 8 - 9

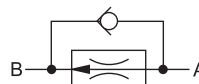

VF02R*

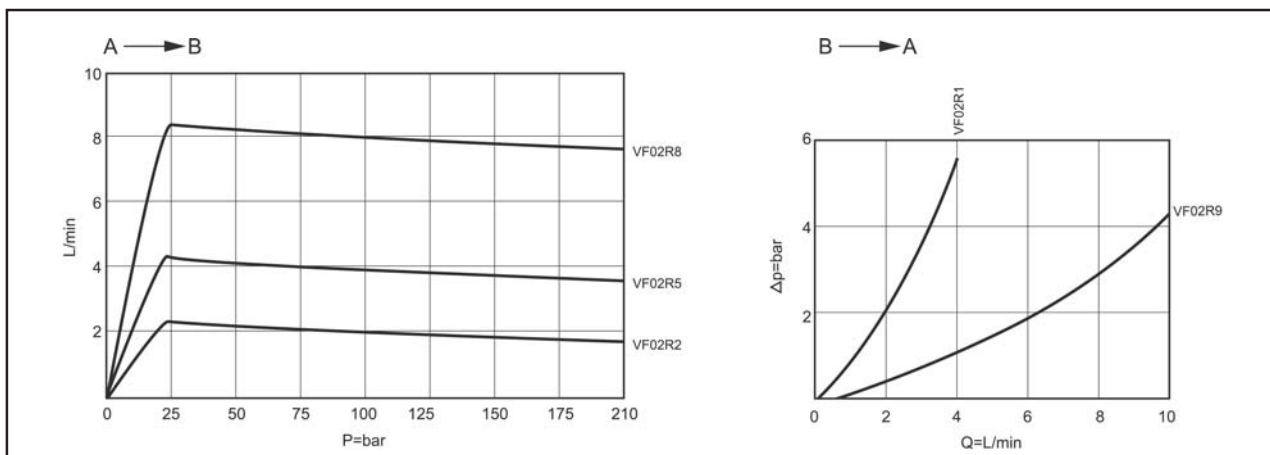



Distribuidores / Control valves

NOMENCLATURA DE REFERENCIAS

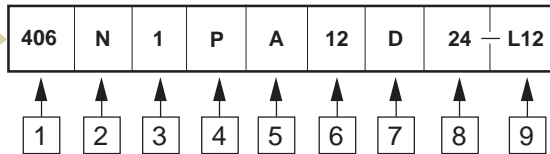

CODING SYSTEMS

1	Tipo distribuidor Control valve type
102 - 1102 - 402 - 302 - 1302 - 406 - 1406 - 504 - 1504 - 407 - 1408	

2	Forma de retorno ó sistema de trabajo Return form
N	Paso libre / Free flow
Z	Retorno con presión / H.P.C.O.
C	Centro cerrado / Closed centre

3	Accionamiento corredera Spool positioning devices	102 1102	402 1402	504 1504	406 1406	407 1407	408 1408	302 1302
1	Tres posiciones recuperación por muellear 5 - 175 bar <i>Three positions, return to neutral by spring</i>	X	X	X	X	X	X	X
2	Tres posiciones con anclajes <i>Three positions with detent</i>	X	X	X	X	X	X	X
3	Dos posiciones extremas empujando corredera <i>Two end positions, action pushing spool</i>	X			X	X		
4	Dos posiciones intermedia y extrema empujando corredera (406 NO) <i>Two positions, action pushing spool</i>	X	X		X	X	X	
5	Microrruptor. Muelle de 5 - 175 bar (1408 NO) <i>Microswitch</i>	X	X	X	X	X		X
6	Doble salida corredera. Muelle de 5 - 175 bar (1408 NO) <i>Double end actioned spool</i>	X	X	X	X			
7	Dos posiciones con anclajes y la tercera por muelle (406 y 1408 NO) <i>Two positions with detent third return by spring</i>	X	X	X	X	X		
8	Los sistemas de accionamiento no son iguales <i>Several operating forms</i>	X	X	X	X	X	X	
9	Dos posiciones extremas con anclajes <i>Two ends positions with detent</i>	X	X	X	X	X	X	X
11	Igual que accionamiento 1, muelle 175 - 250 bar <i>As type 1, spring for 175 - 250 bar</i>	X		X		X		
12	Retorno al punto central por muelle y con palancas tipos: J - U - V - B - R <i>Spring return to neutral with levers type J, U, V, B, R</i>				X			
13	Dos posiciones extremas tirando correderas <i>Two end positions, action pulling spool</i>	X			X			
14	Dos posiciones intermedia y extrema con anclajes empujando corredera (con aro) <i>Two positions, neutral and end with detents pushing spool (with circlip)</i>	X		X				
15	Igual que accionamiento 5, muelle 175 - 250 bar <i>As type 5, spring for 175 - 250 bar</i>	X		X				
16	Igual que 6, muelle 175 - 250 bar <i>As type 6, spring for 175 - 250 bar</i>	X		X				
17	Tres posiciones pilotaje hidráulico <i>Three positions hydraulic piloted</i>			X	X	X	X	
18	Cuatro posiciones ancladas tirando palanca <i>Four detent positions pulling the hand lever</i>						X	
19	Cuatro posiciones, tres normales y la cuarta anclada empujando corredera <i>Four positions, three return by spring the fourth detented pushing spool</i>						X	
20	Cuatro posiciones, tres normales y la cuarta anclada tirando corredera <i>Four positions, three return by spring the fourth detented pulling spool</i>	X	X		X	X	X	X
22	Tres posiciones pilotaje neumático <i>Three positions pneumatic pilot</i>	X	X	X	X	X		
35	Accionamiento rotativo <i>Rotativo detent</i>	X	X	X	X	X	X	
36	Igual que accionamiento 7, pero anclaje apretando corredera <i>As type 7, but detent pushing spool</i>	X						
37	Accionamiento doble, dos correderas con una palanca <i>Double action, two spools with one lever</i>			X				X
42	Tres posiciones con anclajes (con bolas) <i>Three positions with ball-bearing detents</i>	X	X	X				
47	Tres posiciones pilotaje neumático correderas sensibilizadas <i>Three position pneumatic pilot with proportional spools</i>		X	X	X	X		
49	Dos posiciones extremas con anclajes (con bolas) <i>Two end positions with ball-bearing detents</i>			X				
51	Accionamiento eléctrico-hidráulico proporcional alimentación interna (Sólo 402,1402, 406,1406) <i>Proportional electro-hydraulic with internal pilot (only 402, 1402, 406, 1406)</i>		X		X			
52	Accionamiento eléctrico-hidráulico proporcional alimentación externa (Sólo 402,1402, 406,1406) <i>Proportional electro-hydraulic with external pilot (only 402, 1402, 406, 1406)</i>		X		X			
55	Accionamiento eléctrico-neumático <i>Electro-pneumatic action</i>				X			
63	Dos posiciones extremas con doble salida corredera <i>Two end positions with double-ended spool</i>	X						
81	Acción, eléctrico-hidráulico todo-nada. Alimentación interna (Sólo 402, 1402, 406, 1406) <i>On/off electro-hydraulic with internal pilot (only 402, 1402, 406, 1406)</i>		X		X			
82	Acción, eléctrico-hidráulico todo-nada. Alimentación externa (Sólo 402, 1402, 406, 1406) <i>On/off electro-hydraulic with external pilot (only 402, 1402, 406, 1406)</i>		X		X			
83	Accionamiento por electroimán directo, tres posiciones centraje por muelle. <i>Direct solenoid operated, three positions spring centred.</i>							X
84	Accionamiento por electroimán directo, posición central y extrema. Electroimán lado toma A. <i>Direct solenoid operated, two positions (centre+one end). Solenoid side port A.</i>							X



NOMENCLATURA DE REFERENCIAS

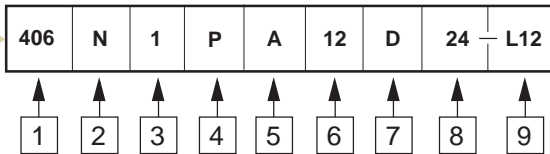

CODING SYSTEMS

4 Tipo de palanca mando <i>Hand lever type</i>	102 1102	402 1402	406 1406	504 1504	407	1408	302 1302
C Tapa con palanca sin protector <i>Lever without bellows</i>					X	X	
P Standard (palanca con protector) <i>Standard (lever with protective bellows)</i>	X	X	X	X			
H Igual que tipo «C» pero sin palanca <i>As type «C» but without lever</i>					X	X	
X Cuando lleve palancas diferentes ó múltiples <i>When different handles or joysticks are fitted</i>							X
Y Para accionamiento 17 (pilotaje hidráulico) <i>For control type 17 (hydraulic piloted)</i>			X	X	X	X	
Z Igual que tipo "P" pero sin palanca <i>As type "P" but without lever</i>	X	X	X	X			
I Accionamiento por cable <i>Cable operated</i>							X
S Sin palanca y tapa sin orejas <i>When no lever needed, a cover without ears will be assembled</i>							X
P2 Palanca roscada doble con protección <i>Double threaded lever with bellows</i>				X			X

5 Posición válvula de seguridad o entrada presión <i>Relief valve position</i>			
102-1102 402-1402	A		A
		406-1406	
504-1504 302-1302	C		C
		407-1408	<div style="display: flex; justify-content: space-around;"> <div style="text-align: center;"> B </div> <div style="text-align: center;"> D </div> </div>

6 Taraje válvula seguridad <i>Relief valve pressure range</i>					
Tipo regulación / Adjustment				Gama de taraje Pressure range bar	
Fija (A) Pre-set	Regulable (B) Adjustable	Volante (C) Knob	Precinto (D) Sealed		
1	11	21	41	5-80	(A) Solo 102-1102 Only
2	12	22	42	85-175	(B) Todos los tipos All types
3	13	23	43	180-250	(C) Solo 102-1102 Only
4	14	24	44	255-350	(D) Solo 102-1102-402-1402-406-1406 Only

Para distribuidores sin válvula de seguridad se omitirá el número de taraje, y en los tipos 102 y 1102 también la letra que indica la posición.
For valves without reliefs the pressure range number is omitted and for 102 and 1102 also the relief position letter.

7 Sistemas de distribución <i>Spool types</i>	
Ver símbolos en paginas correspondientes. / See symbols in relevant pages.	
NOTA: El orden de las correderas se empieza a contar a partir de la válvula de seguridad.	
NOTE: The spool order will be listed from the pressure to the return port.	

8 Gama de tensiones para C.C. (sólo para accionamiento 81-82) <i>D.C. voltage (only for control types 81-82)</i>	
12	12V
24	24V

9 Con válvula puesta en vacío eléctrica <i>With electrical unloading valve</i>		
L12-L24	Eléctrica / <i>Eléctrica</i> 12V-24V	Sólo distribuidor Only control valve
H	Pilotaje hidráulico / <i>Hydraulic piloted</i>	402-1402-406-1406-504-1504



Distribuidores en serie / Serial control valves

102-1102 (Monoblock)



Datos técnicos hidráulicos / Hydraulic technical data		102-1102
Presión máxima de trabajo / Max. working pressure		350 bar

Opciones de montaje / Mounting options
-Sin válvula de seguridad / Without relief valve
-Retorno con presión / Pressure carry over
-Centro cerrado / Closed centre
-Válvulas aspiración / Suction valve

Datos técnicos hidráulicos / Hydraulic technical data		102
Caudal nominal / Nominal flow rate		40 l/min.
Nº elementos / Spool quantity		1 - 6
Tomas / Ports		3/8" BSP

Datos técnicos hidráulicos / Hydraulic technical data		1102
Caudal nominal / Nominal flow rate		60 l/min.
Nº elementos / Spool quantity		1 - 2
Tomas / Ports		1/2" BSP

Sistemas de distribución / Spool types

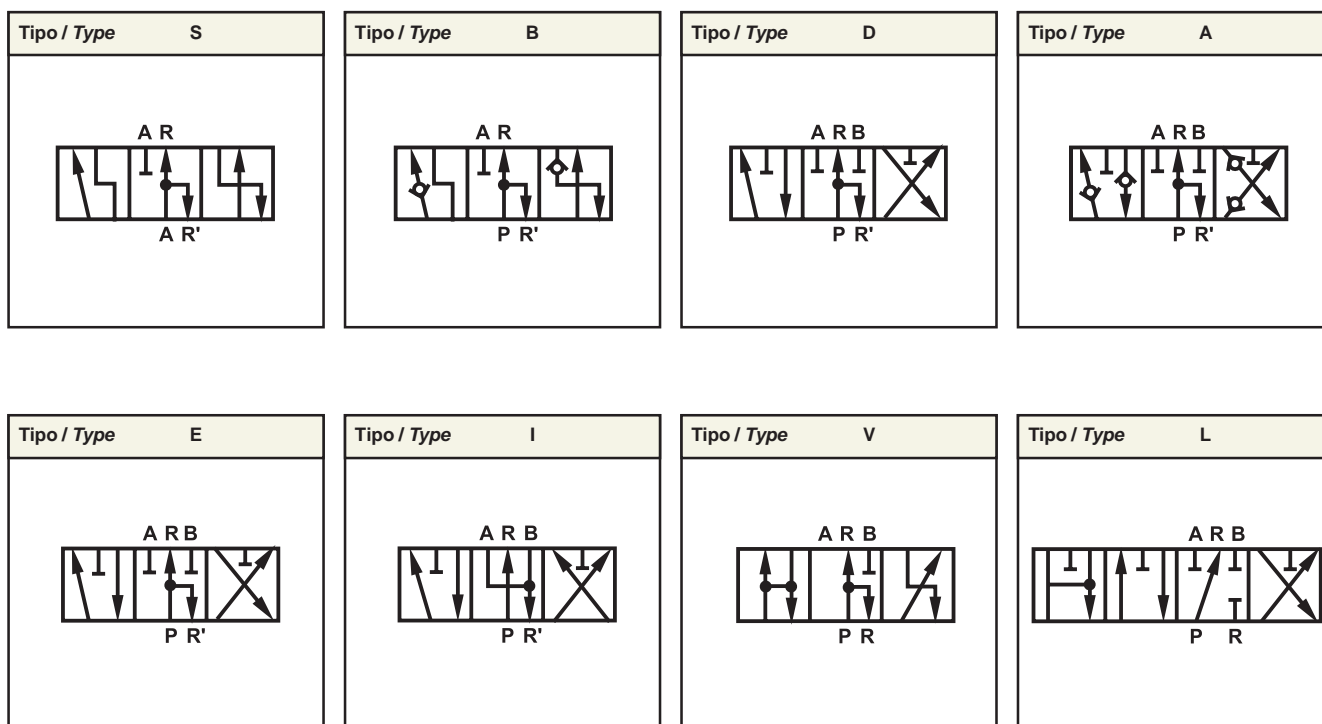

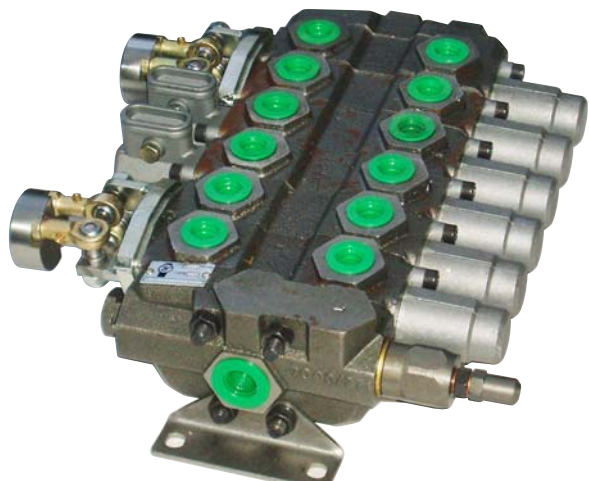

Datos técnicos hidráulicos / Hydraulic technical data		402
Presión máxima de trabajo / Max. working pressure		350 bar
Caudal nominal / Nominal flow rate		50 l/min.
Nº elementos / Spool quantity		1 - 7
Tomas / Ports		3/8" BSP

Opciones de montaje / Mounting options
-Sin válvula de seguridad / Without relief valve
-Retorno con presión / Pressure carry over
-Centro cerrado / Closed centre
-Válvulas auxiliares / Port valves
-Válvulas sobrepresión / Overload valves
-Válvulas aspiración / Suction valve
-Válvula puesta en vacío / Unloading Valve
-Válvula sobrepresión y anticavitación / Overload and anticavitation valves

Sistemas de distribución / Spool types

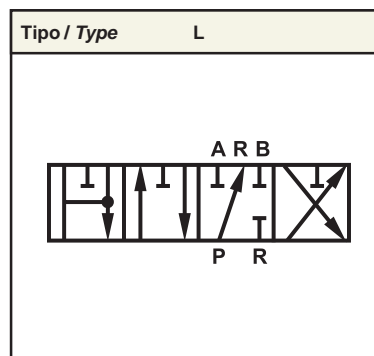
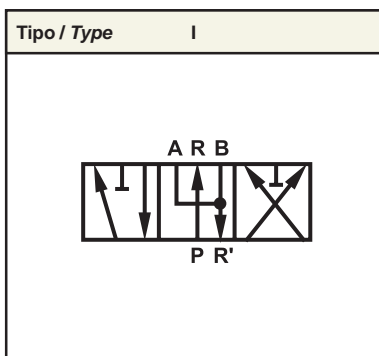
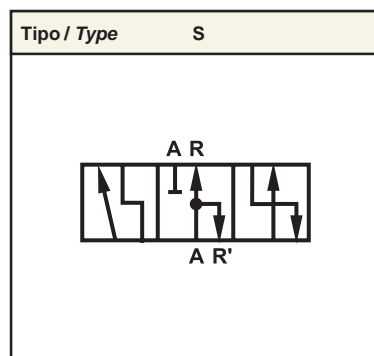
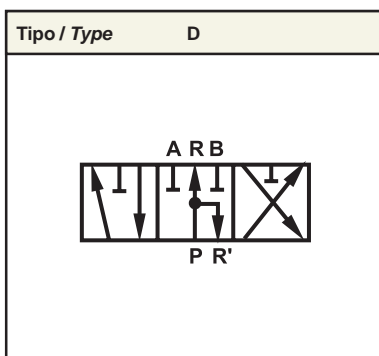



Distribuidores / Control valves

Distribuidores en paralelo / Parallel control valves 302-1302 (Monoblock)



Datos técnicos hidráulicos / Hydraulic technical data		302-1302
Presión máxima de trabajo / Max. working pressure		350 bar
Caudal nominal / Nominal flow rate		60 l/min.
Nº elementos / Spool quantity		1 - 6
Tomas / Ports		3/8" BSP
Tomas 1/2" opcionales bajo pedidos mínimos. Ports 1/2" under minimum quantities.		



Opciones de montaje / Mounting options
-Sin válvula de seguridad / Without relief valve
-Retorno con presión / Pressure carry over
-Centro cerrado / Closed centre
-Válvulas sobrepresión / Overload valves
-Válvulas aspiración / Suction valve
-Válvula sobrepresión y anticavitación / Overload and anticavitation valves

Sistemas de distribución / Spool types

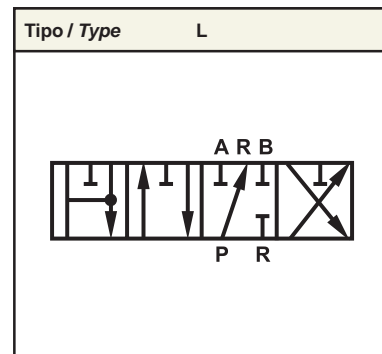
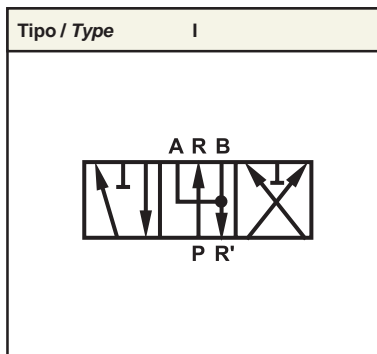
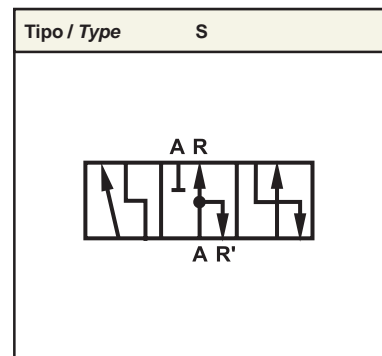
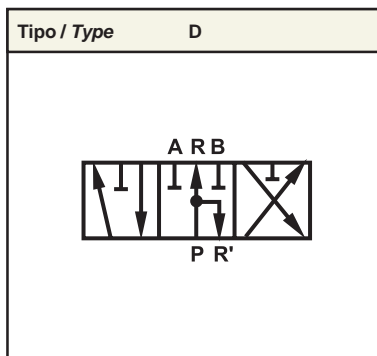



Datos técnicos hidráulicos / Hydraulic technical data		406 - 1406
Presión máxima de trabajo / Max. working pressure		350 bar
Caudal nominal / Nominal flow rate		100 l/min.
Nº elementos / Spool quantity		1 - 7
Tomas / Ports		1/2" BSP

Opciones de montaje / Mounting options
-Sin válvula de seguridad / Without relief valve
-Retorno con presión / Pressure carry over
-Centro cerrado / Closed centre
-Válvulas auxiliares / Port valves
-Válvulas sobrepresión / Overload valves
-Válvulas aspiración / Suction valve
-Válvula puesta en vacío / Unloading valve
-Válvula sobrepresión y anticavitación / Overload and anticavitation valves

Sistemas de distribución / Spool types

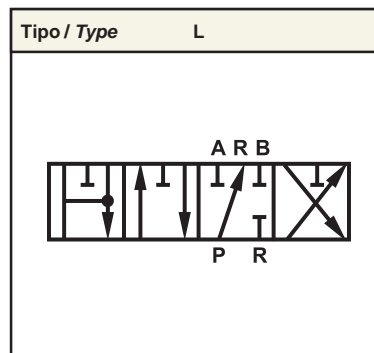
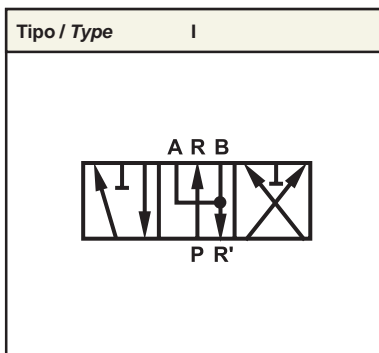
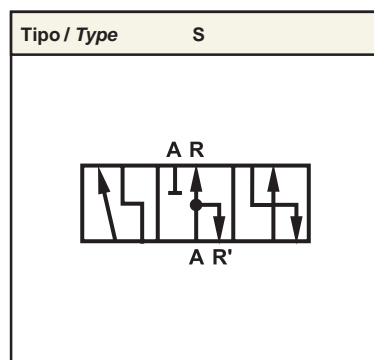
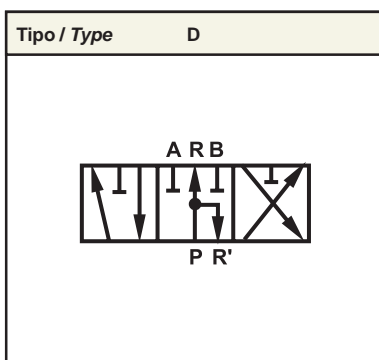

NOTA: En el distribuidor 406 las correderas de cuatro posiciones sólo podrán montar en el último elemento y no es posible retorno con presión.
 NOTE: 406 valve can only have a 4-position spool as the final spool and HPCO is not possible.



Distribuidores en paralelo / Parallel control valves 504-1504 (Monoblock)



Datos técnicos hidráulicos / Hydraulic technical data	504-1504
Presión máxima de trabajo / Max. working pressure	350 bar
Caudal nominal / Nominal flow rate	80 l/min.
Nº elementos / Spool quantity	1 - 7
Tomas / Ports	1/2" BSP

Opciones de montaje / Mounting options

- Sin válvula de seguridad / Without relief valve
- Retorno con presión / Pressure carry over
- Centro cerrado / Closed centre
- Válvulas auxiliares / Port valves
- Válvulas sobrepresión / Overload valves
- Válvulas aspiración / Suction valve
- Válvula puesta en vacío / Unloading valve
- Válvula sobrepresión y anticavitación / Overload and anticavitation valves

Sistemas de distribución / Spool types

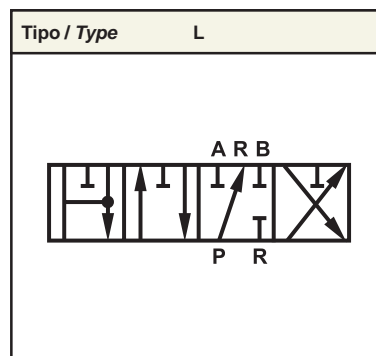
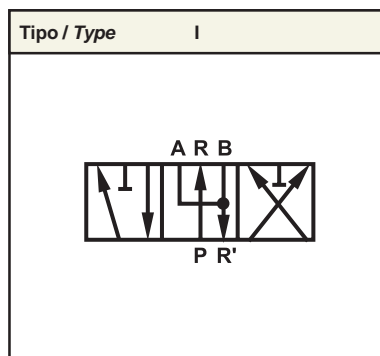
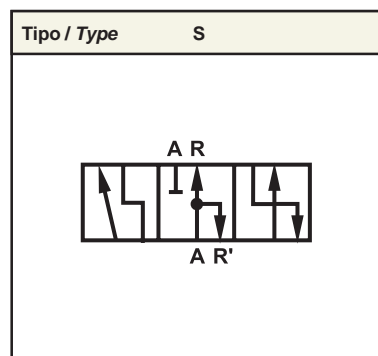
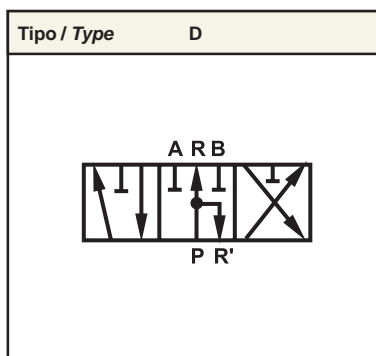
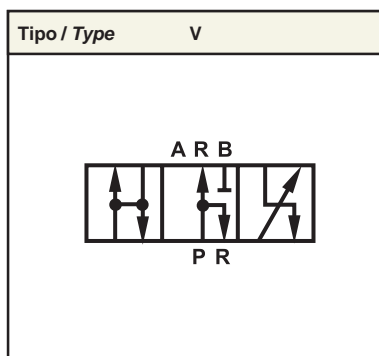



Distribuidores en paralelo / Parallel control valves 407-1408 (Sandwich)



Datos técnicos hidráulicos / Hydraulic technical data 407-1408

Presión máxima de trabajo / Max. working pressure 350 bar

Opciones de montaje / Mounting options

- Sin válvula de seguridad / Without relief valve
- Retorno con presión / Pressure carry over
- Centro cerrado / Closed centre
- Válvulas sobrepresión / Overflow valve
- Válvulas aspiración / Suction valve

Datos técnicos hidráulicos / Hydraulic technical data 407

Caudal nominal / Nominal flow rate	150 l/min.
Nº elementos / Spool quantity	1 - 6
Tomas / Ports	3/4" BSP

Datos técnicos hidráulicos / Hydraulic technical data 1408

Caudal nominal / Nominal flow rate	300 l/min.
Nº elementos / Spool quantity	1 - 6
Tomas / Ports	1" BSP

Sistemas de distribución / Spool types

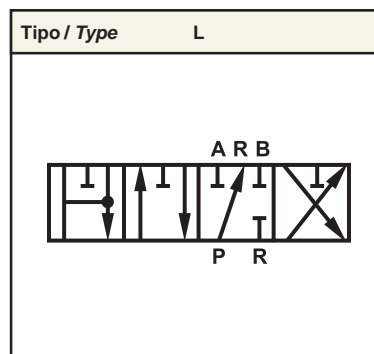
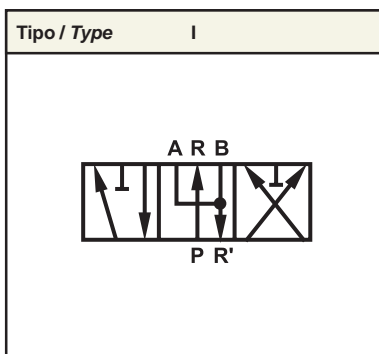
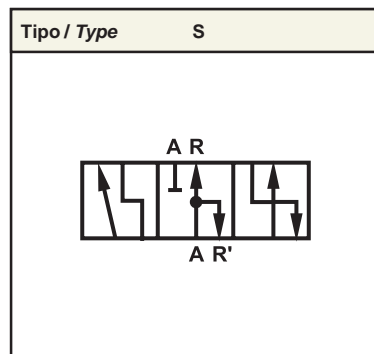
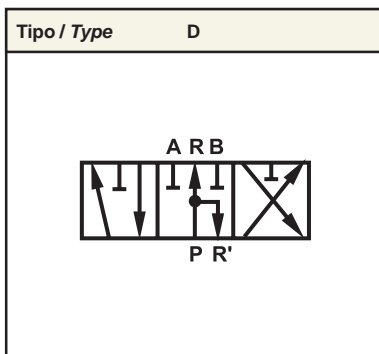



TN-6 & TN-10 / NG-6 & NG-10



Referencia TN-6 Reference NG-6								
5EV	P	◆	D	■	C B	02	R D	*

Referencia TN-10 Reference NG-10								
2EV	P	◆	D	■	C B	03	R C	*

Dos posibles accionamientos

Two kind of drive:

- 2EV Accionamiento eléctrico
Electric drive

* Tension y frecuencia

Voltage & frequency

AC = 24V - 48V - 110V - 220V (50Hz)
24V - 48V - 115V - 230V (60Hz)
DC = 12V - 24V - 48V

Vías / Ways

C = 4
B = 3

Tipo corriente / Current type

D = Continua / Direct
R = Alterna / Alternative

Datos técnicos hidráulicos / Hydraulic technical data

Presión máxima de trabajo / Max. working pressure	350 bar
Caudal nominal TN-6 / Nominal flow rate NG-6 CETOP 3	80 l/min.
Caudal nominal TN-10 / Nominal flow rate NG-10 CETOP 5	100 l/min.
Voltage / Voltage	DC o AC

Sistemas de control Control systems	
1	Dos posiciones un electroimán . (Solo formas 7-8 y 17-18) Two positions one solenoid. (Forms 7-8 & 17-18)
2	Dos posiciones dos electroimanes. Two positions two solenoids.
●3	Tres posiciones dos electroimanes. Three positions two solenoids.
●12	Dos posiciones central y extrema (A). Two positions neutral & end one (A).
●13	Dos posiciones central y extrema (B). Two positions neutral & end one (B).
14	Dos posiciones extrema y central (A). Two positions end & neutral (A).
●29	Dos posiciones extremas con anclaje mecánico. Two positions with detent.

Forma Type	Simbolo Symbol
1	(A) (B)
2	(A) (B)
3	(A) (B)
4	(A) (B)
5	(A) (B)
6	(A) (B)
13	(A) (B)
2	(A) (B)
2	(A) (B)
4	(A) (B)
7	(A) (B)
8	(A) (B)
17	(A) (B)
18	(A) (B)

TN-6 / NG-6 CETOP 3

Δp-Q at 23 cSt

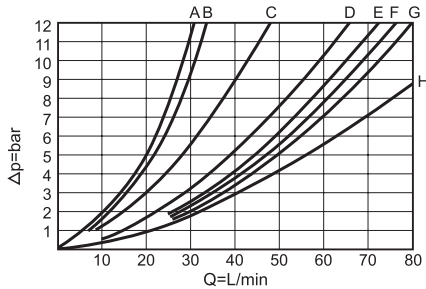

Forma Corredera / Spool form

Posición Position	1	2	3	4
P → A & P → B	A	D	D	E
A → R & B → R	B	E	H	G
P → R	C	-	-	F

Límites de funcionamiento / Operation limits

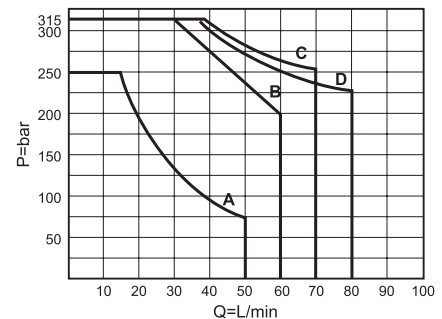

Curva / Curve

Forma Corredera Spool form	A	B	C	D
	7 - 17	1	8 - 18	2 - 3 - 4 5 - 6 - 13

TN-10 / NG-10 CETOP 5

Δp-Q at 23 cSt

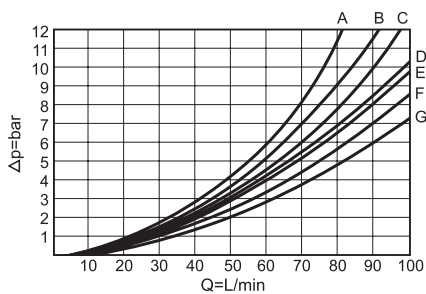

Forma Corredera / Spool form

Posición Position	1	2	3	4
P → A & P → B	E	F	F	G
A → R & B → R	A	E	E	D
P → R	B	-	-	C

Límites de funcionamiento / Operation limits

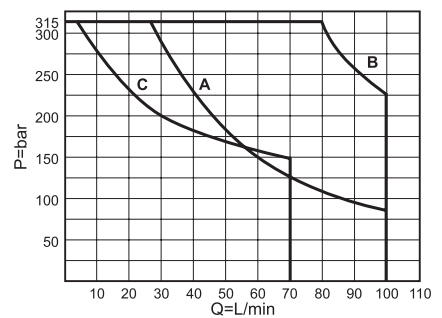

Curva / Curve

Forma Corredera Spool form	A	B	C
	1 - 6	1 - 2 - 3 - 4 5 - 8 - 13 - 18	7 - 17



Electroválvulas / Solenoid operated valves

TN-16 - TN-25 - TN-32 / NG-16 - NG-25 - NG-32

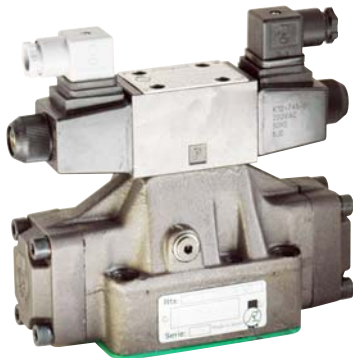

Datos técnicos hidráulicos / Hydraulic technical data	
Presión máxima de trabajo / Max. working pressure	350 bar
Caudal nominal TN-16 / Nominal flow rate NG-16 CETOP 7	200 l/min.
Caudal nominal TN-25 / Nominal flow rate NG-25 CETOP 8	350 l/min.
Caudal nominal TN-32 / Nominal flow rate NG-32 CETOP 10	700 l/min.

■ Forma Type	Ⓐ Símbolo Symbol	Ⓑ
1		
2		
2		
3		
4		
5		
6		
2		

Referencia TN-6 Reference NG-6									
5EV	P	◆	P D	■	C B	05 06 12	D R	*	▲

Tipo electroválvula / Solenoid controlled valve type

P = Pilotada / Piloted
D = Directa / Direct

Vías / Ways

C = 4
B = 3

Tamaño / Size

05 = TN16
06 = TN25
12 = TN32

Tipo corriente / Current type

D = Continua / Direct
R = Alterna / Alternate

* Tensión y frecuencia / Voltage & frequency

AC = 24V - 48V - 110V - 220V (50Hz)
115V - 230V (60Hz)
DC = 12V - 24V

▲ Pilotaje y fugas / Pilot & drain

I = Interno-Externo / Internal-External
E = Externo-Externo / External-External
F = Interno-Interno / Internal-Internal
G = Externo-Interno / External-Internal

◆ Sistemas de control Control systems	
1	Dos posiciones un electroimán. Two positions one solenoid.
2	Dos posiciones dos electroimanes. Two positions two solenoids.
3	Tres posiciones dos electroimanes. Three positions two solenoids.
4	Dos posiciones sin electroimán. Two positions without solenoid.
5	Tres posiciones sin electroimán. Three positions without solenoid.
6	Dos posiciones sin electroimán, recuperación por muelle. Two positions without solenoid, spring return
7	Tres posiciones con anclaje sin electroimán. Three positions with detent without solenoid.
8	Dos posiciones fijas, la tercera con muelle y sin electroimán. Two fixed positions third position with spring without solenoid



GBE

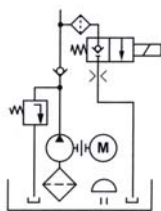

Datos técnicos hidráulicos / Hydraulic technical data	
Presión máxima de trabajo / Max. working pressure	225 bar
Desplazamiento volumétrico (cm ³ /v) / Pump displacement (cc-r)	6-10,6
Capacidad del tanque / Tank capacity	7,5 - 30 l.
Potencia del motor (CV) / Motor power (HP)	0,75 - 10

Motobomba especialmente útil para el accionamiento de cilindros de simple efecto cuyo descenso se efectúa por gravedad. Las aplicaciones más corrientes pueden ser plataformas elevadoras, elevación de vehículos, tapas posteriores para carga y descarga de camiones, etc.

Power packs for single-acting cylinder systems where the load descends by gravity. Typical applications include lift platforms, car lifts, tail lifts for trucks, etc.

MBE

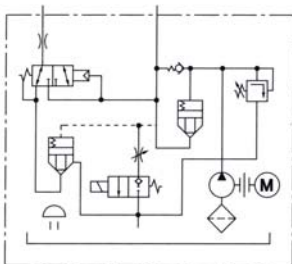

Datos técnicos hidráulicos / Hydraulic technical data	
Presión máxima de trabajo / Max. working pressure	250 bar
Desplazamiento volumétrico (cm ³ /v) / Pump displacement (cc-r)	1 - 5
Capacidad del tanque / Tank capacity	3 - 15 l.
Potencia del motor (CV) / Motor power (HP)	0,33 - 5,5

Motobomba específica para muelles de carga, con el cual se consigue la flotación necesaria en las variaciones de altura del camión en la operación de carga y descarga.

A typical power pack for dock-levelling systems for loading bays-giving full control of the unloading ramp so that it follows movement of the truck as it is loaded or un-loaded.



Motobombas / Hydraulic power pack units

PBE



Datos técnicos hidráulicos / Hydraulic technical data

Presión máxima de trabajo / Max. working pressure	225 bar
Desplazamiento volumétrico (cm ³ /v) / Pump displacement (cc-r)	0,33 - 1
Capacidad del tanque / Tank capacity	1,3 - 2 l.
Potencia del motor (CV) / Motor power (HP)	0,25 - 1

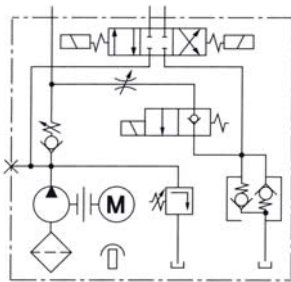

Motobomba especialmente útil para el accionamiento de cilindros de simple efecto cuyo descenso se efectúa por gravedad.

Las aplicaciones más corrientes pueden ser plataformas elevadoras, elevación de vehículos, tapas posteriores para carga y descarga de camiones, etc.

Power packs for single-acting cylinder systems where the load descends by gravity.

Typical applications include lift platforms, car lifts, tailifts for trucks, etc.

Sistemas de control / Control system

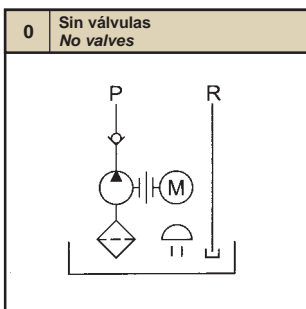

No lleva ningún tipo de válvula
No valve

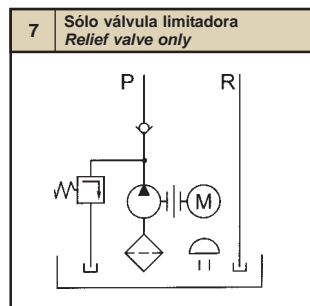
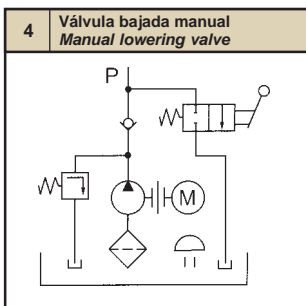
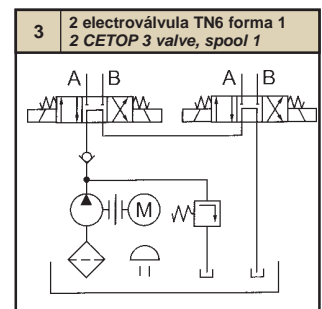
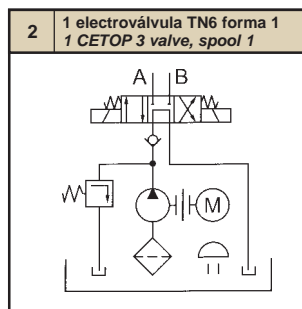
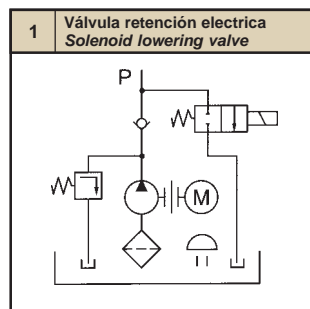

Solo con válvula limitadora
Only relief valve

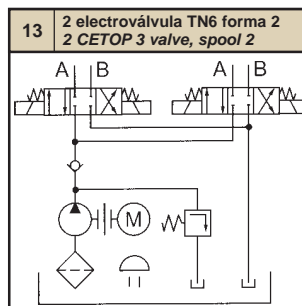

Solo para GBE
Only GBE

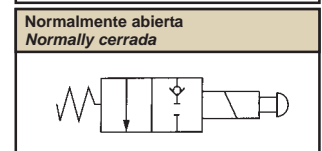
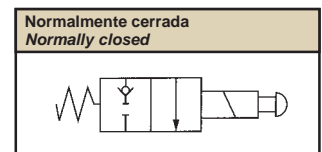



Cilindros PN / *Cylinders PN*

PN 160



Datos técnicos hidráulicos / <i>Hydraulic technical data</i>	
Presión máxima de trabajo <i>Max. working pressure</i>	160 bar
Fluido recomendado <i>Fluid to be used</i>	ISO 6743 - HM, HV, HG
Gama de temperaturas del fluido <i>Fluid temperature range</i>	-20 °C... + 80 °C
Grado de limpieza del aceite <i>Recommended fluid cleanliness</i>	19/16 s/. ISO 4406 - RP70H
Recorrido normalizado <i>Standard stroke</i>	1,5 mts
Velocidad máxima del émbolo <i>Maximum piston speed</i>	hasta 25 m/min.

Nomenclatura de referencias	1DL	1	C	12	25	650	R	Coding system
-----------------------------	-----	---	---	----	----	-----	---	---------------

Tipo cilindro / <i>Cylinder type</i>	
1DL	Doble efecto / <i>Double acting</i>

Tipo juntas / <i>Seals type</i>	
1	Standar / <i>Standard</i>

Fijación del cilindro / <i>Cylinder mounting</i>	
C	Charnela sin fresado / <i>Nonmilled clevis</i>
E	Charnela con fresado / <i>Milled clevis</i>
F	Brida frontal / <i>Front flange</i>
G	Charnela con rótula / <i>Self aligning clevis</i>
M	Bulones o Muñones / <i>Trunnions</i>
P	Patas / <i>Feet</i>

Fijación del vástago / <i>Piston rod end</i>	
C	Por charnela / <i>Clevis</i>
G	Charnela con rótula / <i>Self aligning clevis</i>
R	Vástago roscado / <i>Standard threaded</i>

Carreras standar en mm. / <i>Standard stroke in mm.</i>				
50	75	100	150	200
250	300	400	500	600
800	1000	1250	1500	

Diámetros émbolo en mm. / <i>Bore diameter in mm.</i>				
25	32	40	50	63
70	80	100	125	

Diámetro del vástago / <i>Rod diameter</i>				
12	18	22	28	36
40	45	56	70	

Fijación del cilindro / *Cylinder mounting*

Forma C, E, G



Forma P



Forma M

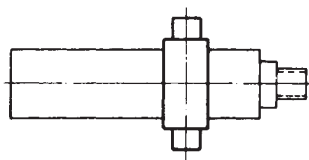

Forma F

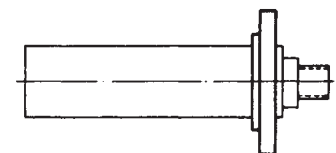

Fijación del vástago / *Piston rod end*

Forma C

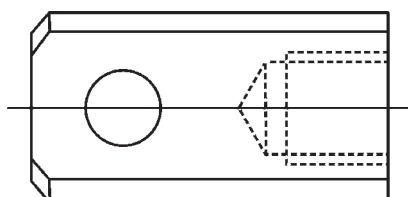

Forma G

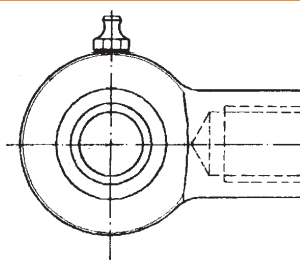



Cilindros PN / *Cylinders PN*

PN 250



Datos técnicos hidráulicos / <i>Hydraulic technical data</i>	
Presión máxima de trabajo <i>Max. working pressure</i>	250 bar
Fluido recomendado <i>Fluid to be used</i>	ISO 6743 - HM, HV, HG
Gama de temperaturas del fluido <i>Fluid temperature range</i>	-20 °C... + 80 °C
Grado de limpieza del aceite <i>Recommended fluid cleanliness</i>	19/16 s/. ISO 4406 - RP70H
Recorrido normalizado <i>Standard stroke</i>	1,5 mts
Velocidad máxima del émbolo <i>Maximum piston speed</i>	hasta 25 m/min. to

Nomenclatura de referencias		DS	1	P	45	80	600	R	Coding system		
Tipo cilindro / <i>Cylinder type</i>										Fijación del vástago / <i>Piston rod end</i>	
DS	Doble efecto / <i>Double acting</i>									C	Por charnela / <i>Clevis</i>
Tipo juntas / <i>Seals type</i>										Q	Charnela con casquillo / <i>Clevis with bronze bush</i>
1	Standar / <i>Standard</i>									G	Charnela con rótula / <i>Self aligning clevis</i>
Fijación del cilindro / <i>Cylinder mounting</i>										R	Vástago roscado / <i>Standard threaded</i>
C	Charnela / <i>Clevis</i>									Carreras standar en mm. / <i>Standard stroke in mm.</i>	
Q	Charnela con casquillo / <i>Clevis with bush</i>									50 - 100 - 150 - 200 - 250 - 300 - 400 - 500 - 600	
G	Charnela con rótula / <i>Self aligning clevis</i>									800 - 1000 - 1250 - 1500 - 1750 - 2000 - 2250	
P	Patas / <i>Feet</i>									2500 - 2750 - 3000	
M	Bulones o Muñones / <i>Trunnions</i>									Diámetros émbolo en mm. / <i>Bore diameter in mm.</i>	
F	Brida frontal / <i>Front flange</i>									32 - 40 - 50 - 63 - 70 - 80 - 100 - 115 - 125 - 140	
B	Por brida posterior / <i>Rear flange</i>									160 - 180 - 200 - 2250 - 250	
										Diámetro del vástago / <i>Rod diameter</i>	
										18 - 22 - 28 - 36 - 40 - 45 - 50 - 56 - 70 - 80 - 90	
										100 - 110 - 125 - 140 - 160	

Fijación del cilindro / *Cylinder mounting*

Forma / *Form C, E, G*



Forma / *Form P*



Forma / *Form B*

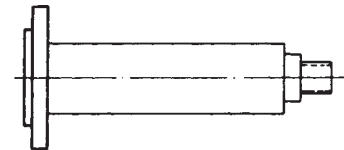

Forma / *Form M*

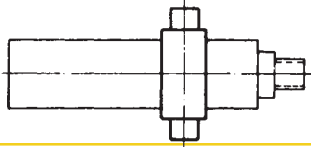

Forma / *Form F*



Fijación del vástago / *Piston rod end*

Forma
Form C, Q

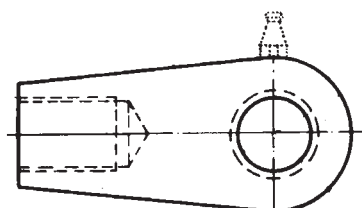

Forma
Form G

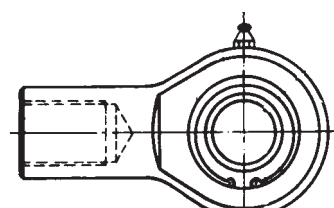



Motores hidraulicos / Hydraulic motors

NOMENCLATURA DE REFERENCIAS

1MGP 80 C 04 / 09 E

CODING SYSTEMS

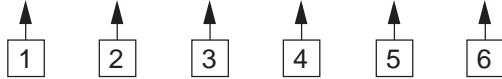

1 Modelo
Model

1 MGP 1 MGR

4 Conexión tomas
Port connections

04	1/2" BSP
----	----------

5 Tipo brida fijación
Fixing flange

09

2 Cilindrada (cm³/v.)
Displacement cc/r

MGP	50 - 63 - 80 - 100 - 125 - 160 - 200 - 250 - 320 - 400 - 500
MGR	50 - 63 - 80 - 100 - 160 - 200 - 250 - 350 - 370 - 395

3 Forma eje motriz
Driving shaft form

C	Cilindro ø25 <i>Parallel</i>
---	---------------------------------

6 Datos adicionales
Additional data

Sentido de giro *Rotation direction*

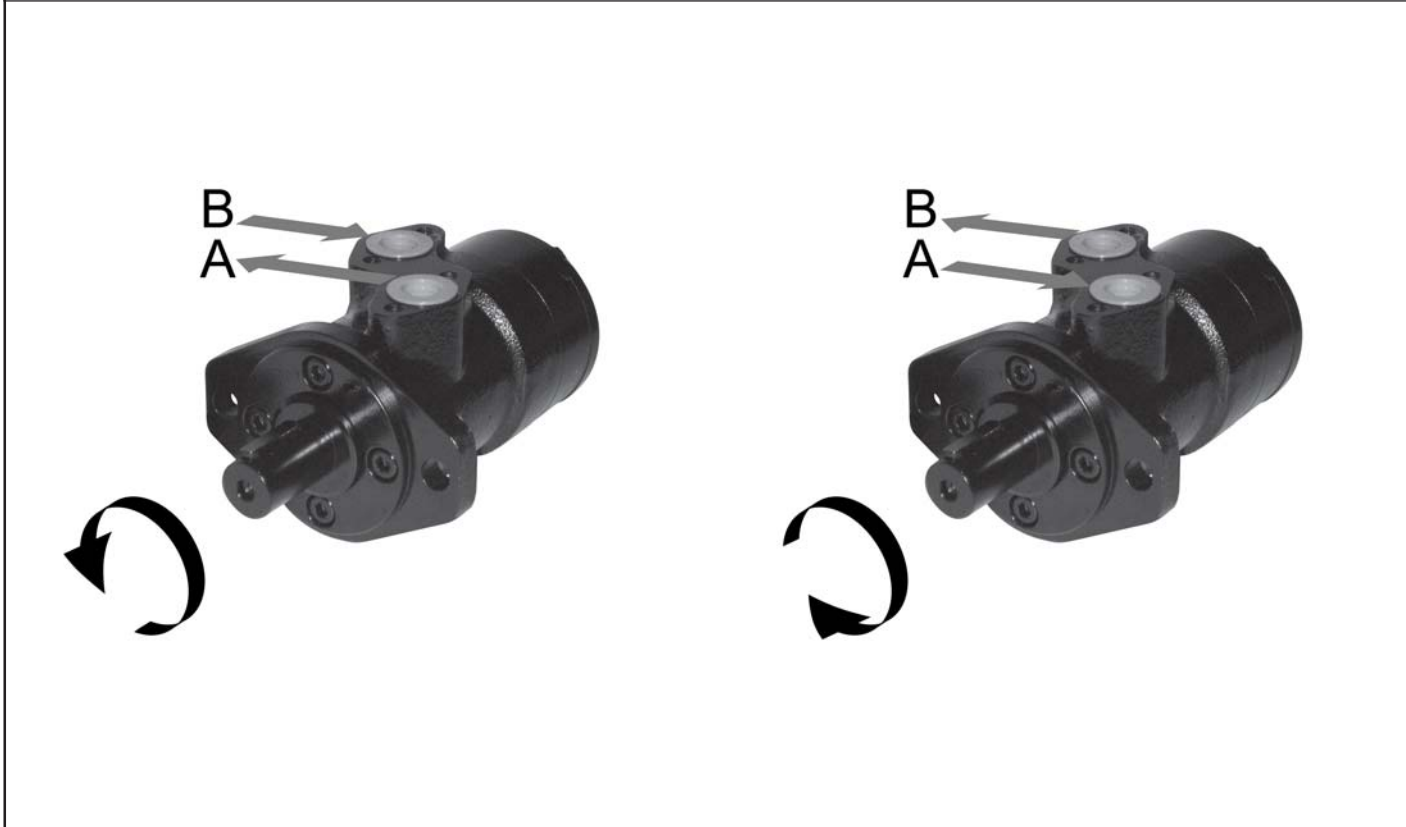



Motores hidraulicos / Hydraulic motors

1MGP

Datos técnicos hidráulicos Hydraulic technical data													
REFERENCIA PART NUMBER			1MGP50	1MGP63	1MGP80	1MGP100	1MGP125	1MGP160	1MGP200	1MGP250	1MGP320	1MGP400	1MGP500
DESPLAZAMIENTO GEOMETRICO (cm ³ /v) VOLUMETRIC DISPLACEMENT (cc/r.)			50	63	80	100	125	160	200	250	320	400	500
PAR MÁXIMO MAX. TORQUE	Nm	Continuo Continuous	73	86	124	154	194	228	285	304	364	466	496
		Intermitente Intermittent	84	93	139	173	216	261	319	378	403	522	516
PRESIÓN MÁXIMA ENTRADA INLET. MAX. PRESSURE	bar	Continuo Continuous	150										
		Intermitente Intermittent	175										
		Punta Peak	225										
VELOCIDAD MÁXIMA MAXIMUM SPEED	r.p.m	Continuo Continuous	698	663	679	558	452	354	284	235	178	145	115
		Intermitente Intermittent	859	774	811	669	544	425	339	281	208	171	136
CAUDAL MÁXIMO ACEITES MAXIMUM OIL FLOW RATE	r.p.m	Continuo Continuous	38	45	57	57	57	57	57	57	57	57	57
		Intermitente Intermittent	45	53	68	68	68	68	68	68	68	68	68
PESO WEIGHT	Kg		5	5,3	5,5	6,1	6,2	6,4	6,7	7,1	7,4	7,7	7,8

1MGR

Datos técnicos hidráulicos Hydraulic technical data												
REFERENCIA PART NUMBER			1MGR50	1MGR63	1MGR80	1MGR100	1MGR160	1MGR200	1MGR250	1MGR305	1MGR370	1MGR395
PAR MÁXIMO MAX. TORQUE	Nm	Continuo Continuous	93	123	155	196	271	328	401	417	402	429
		Intermitente Intermittent	105	138	174	219	297	359	410	441	427	458
PRESIÓN MÁXIMA ENTRADA INLET. MAX. PRESSURE	bar	Continuo Continuous	150									
		Intermitente Intermittent	175									
		Punta Peak	225									
VELOCIDAD MÁXIMA MAXIMUM SPEED	r.p.m	Continuo Continuous	750	778	635	510	329	266	213	171	142	133
		Intermitente Intermittent	875	832	680	537	347	281	226	182	150	141
CAUDAL MÁXIMO ACEITES MAXIMUM OIL FLOW RATE	r.p.m	Continuo Continuous	38	53	53	53	53	53	53	53	53	53
		Intermitente Intermittent	45	57	57	57	57	57	57	57	57	57
PESO WEIGHT	Kg		6,3	6,7	7,0	7,5	7,7	8,0	8,4	8,8	9,4	9,6

Pedro Roquet, s/a

Antonio Figueras, 91
08551 Tona (Barcelona) Spain
Tel. +34 93 812 46 64
Fax +34 93 887 17 98
www.pedro-roquet.com

Distribuidor / Agent: