

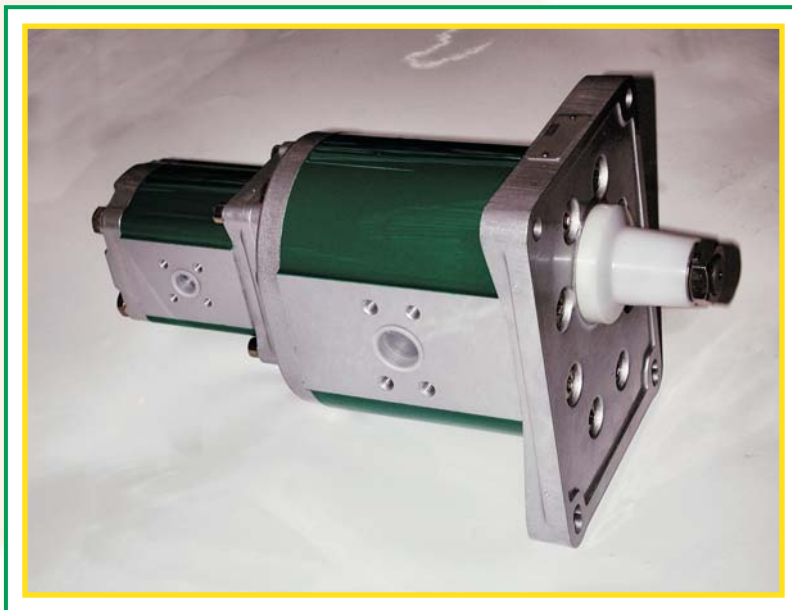

PRODUCT CARD



GEAR PUMPS AND MOTORS "B" SERIES GROUP 3.5

E0.18.0703.02.01



Page 1 - GENERAL INDEX

Page 2 - Features - Quick guide

Page 3 - Features - General - Working conditions - Fire resistant fluid

Page 4 - Features - Drive shaft - Pump rotation direction - Hydraulic pipe lines

Page 5 - Features - Filtration index recommended - Tightening torque - Common formulas

Page 6 - Features - Identification label

Page 7 - Features - Changing rotation instructions

Page 8 - 3.5P/MC GROUP 3.5

Page 9 - Assembling dimensions and values of pressure and speed

Page 10 - Version interchangeable with 4PB

Page 11 - Flanged ports

Page 12 - Drive shafts

Page 13 - Mounting flanges

Page 14 - Outrigger bearing

Page 15 - Multiple gear pumps - Assembling dimensions

Page 16 - 3.5PC combination with 3PB

Page 17 - 3.5PC combination with 2PB (communicating inlet ports) -
- 3.5PC combination with 2PB with separated stages

Page 18 - 19 - Pump performance curves

Page 20 - Port connectors

Page 21 - How to order - Single pumps/motors

Page 22 - How to order - Multiple pumps

Page 23 - WARRANTY

E0.18.0703.02.01

The data in this catalogue refers to the standard product.

The policy of Salami S.p.A. consists of a continuous improvement of its products. It reserves the right to change the specifications of the different products whenever necessary and without giving prior information.

If any doubts, please get in touch with our sales department.

QUICK GUIDE TO SELECT THE RIGHT PUMP SIZE

Definition of pressures

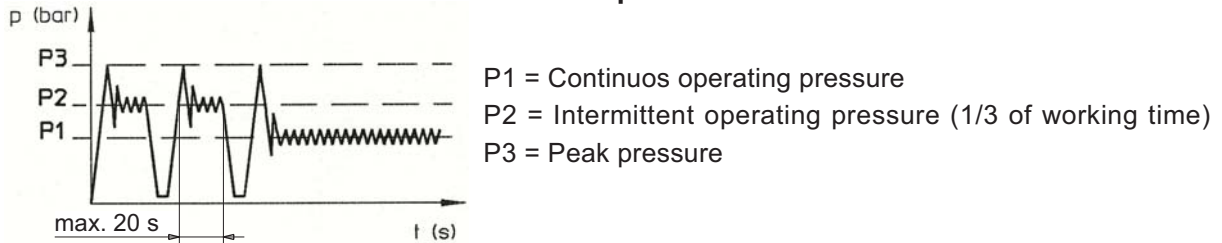

The diagram shown here below is used as a first dimensioning aid for the choice of pump group. It is based on the value of displacements (horizontal coordinates) and intermittent pressure P2 (vertical coordinates)

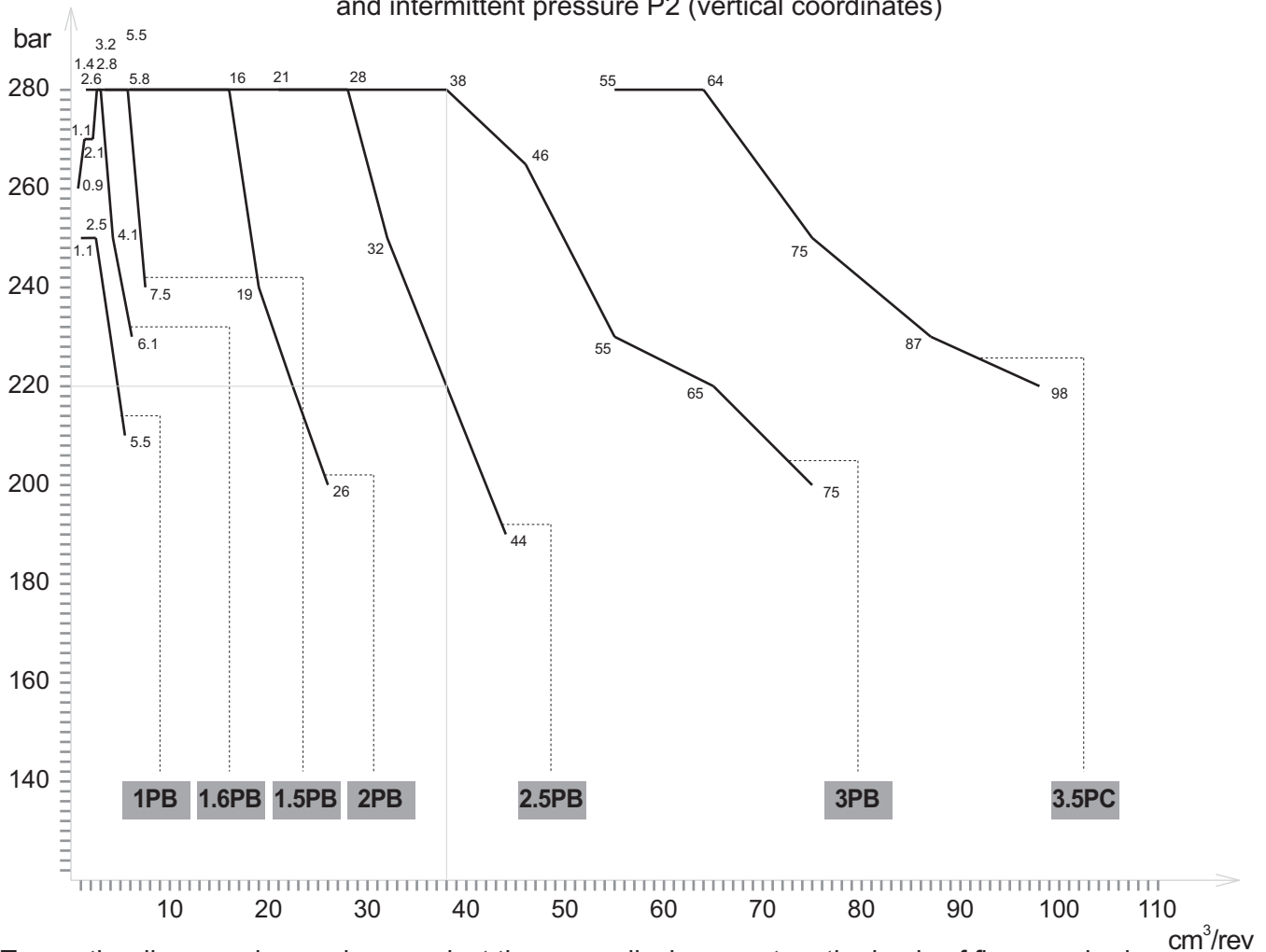

To use the diagram shown above, select the pump displacement on the basis of flow required. Then draw a vertical line to intersect the line representing the pump series. Now you can select the group on the basis of required application pressure.

Example: 38 cm^3/rev — 2.5PB 38 220 bar (3140 psi)
If required application pressure is more than 220 bar, use a 3 PB



GENERAL

SALAMI gear pumps and motors are available in seven series giving options of displacements from 1.1 cm³/rev to 98 cm³/rev (from 0.06 cu.in./rev to 6.03 cu.in./rev).

All pumps are available as multiple units either of the same or different series.

With all sizes of pumps and motors there are options of shafts, flanges and ports as for European, German and American standards.

SALAMI gear pumps and motors offer:

- High volumetric efficiency by innovative design and accurate control of machining tolerances.
- Axial compensation achieved by the use of floating bushes that allow high volumetric efficiency throughout the working pressure range.
- DU bearings ensure high pressure capability.
- 12 teeth integral gear and shaft.
- Extruded alluminum body.
- Die cast alluminum cover and flange - cast iron rear.
- Double shafts seals in all pump series except Group 1.
- Nitrile seals as standard and viton seals in high temperature applications.

All pumps and motors are hydraulic tested after assembly to ensure the high standard performance required by SALAMI'S engineering.

WORKING CONDITIONS

THE VALUES OF PRESSURE ARE ABSOLUTE

- Pump inlet pressure 0,7 to 2,5 bar
10 to 36 *psi*
- Return pipe line continuous pressure for motors MAX 2,5 bar - 36 *psi*
- Return pipe line intermit. pressure for motors MAX 6 bar for 15 sec - 85 *psi*
- Return pipe line peak pressure for motors MAX 15 bar - 215 *psi*
- Minimum operating fluid viscosity 12 mm² / sec
- Max starting viscosity 800 mm² / sec
- Suggested fluid viscosity range 17 - 65 mm² / sec
- Fluid operating temperature range -15 to +85 °C
- Hydraulic fluid mineral oil

Important:

in case of assembling of pumps without shaft seals (eg. B2 - B3...), you have to keep the value of min. suction pressure (0.7 bar (abs)) in the vane between pump and coupling too.

Lower pressure can lead to suction of oil through the front flange (seat of the shaft without seal); this can damage seriously the pump.

FIRE RESISTENT FLUID

Type	Description	Max pressure	Max speed (rpm)	Temperature
HFB	oil emulsion with 40% water	130 bar/1880 <i>psi</i>	2500	3°C +65°C
HFC	Water glycol	180 bar/2600 <i>psi</i>	1500	-20°C +65°C
HFD	Phosphate esters		1750	-10°C +80°C

DRIVE SHAFT

Radial and axial loads on the shafts must be avoided since they reduce the life of the unit. Pumps driven by power take - off on engines must always be connected by placing an "Oldham" coupling or coupling having convex toothed hub. This is to ensure that inevitable misalignment during assembly is reduced to minimum.

PUMP ROTATION DIRECTION VIEWED AT THE DRIVE SHAFT

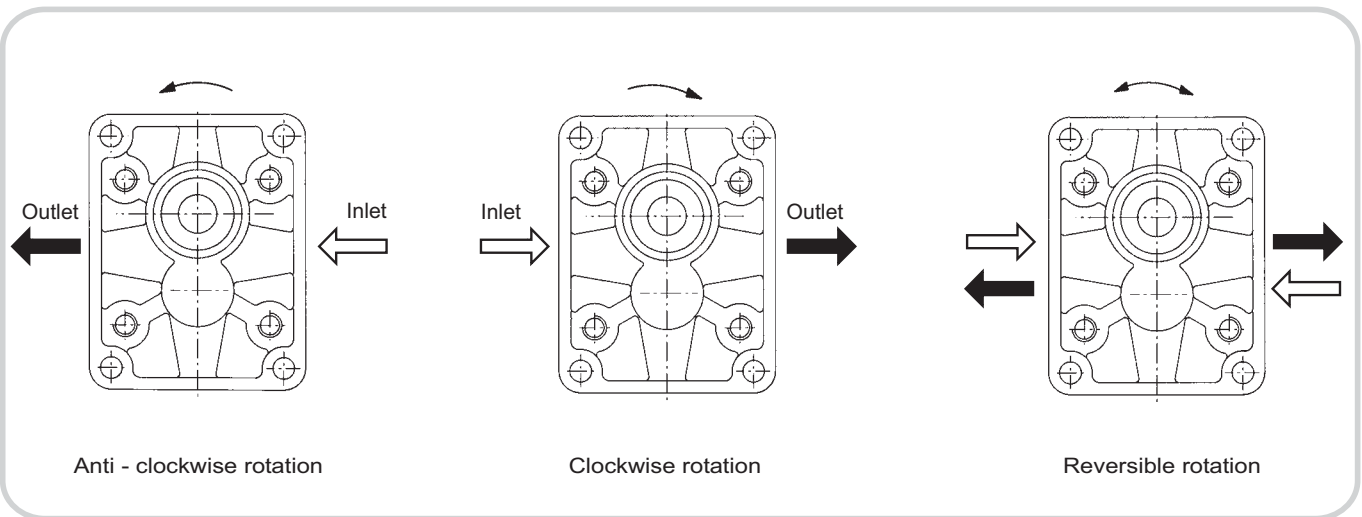

HYDRAULIC PIPE LINE

To ensure favorable suction conditions it is important to keep pressure drop in suction pipe line to a minimum value (see WORKING CONDITIONS).

To calculate hydraulic pipe line size, the designer can use; as an approximate guide, the following fluid speed figures:

From 1 to 2 m/sec on suction pipe line
From 6 to 10 m/sec on pressure pipe line

From 3.28 to 6.36 ft/sec on suction pipe line
From 19.7 to 32.8 ft/sec on pressure pipe line

The lowest fluid speed values in pipe lines is recommended when the operating temperature range is high and/or for continuous duty.

The highest value is recommended when the temperature difference is low and/or for intermittent duty.

When tandem pumps are supplied by 2 different reservoirs with 2 different fluids it is necessary to specify "AS" version.

In case of reversible motor allowance must be made to ensure the motor is not drained, through the case drain, when stationary.



FILTRATION INDEX RECOMMENDED

Working pressure	> 200 bar / 2900 psi	< 200 bar / 2900 psi
Contamination class NAS 1638	9	10
Contamination class ISO 4406	18/15	19/16
Achieved with filter $\beta_x = 75$	15 μm	25 μm

TIGHTENING TORQUE

OUR BOLTS AND TIE-RODS HAVE ALWAYS HEATING TREATMENT OF BLACK BURNISHING

PUMP TYPE		BOLT TYPE		TORQUE Nm	FOR SCREWS ZINC PLATED REDUCE TIGHTENING TORQUE OF 10%
SIZE	SERIE	DIAMETER	CLASS		
1	B SINGLE	M 8 x 1.25	8.8	20.5 - 25.5	
1	B MULTIPLE	M 8 x 1.25	8.8	20.5 - 25.5	
2	B SINGLE	M 10 x 1.5	8.8	47-51	
2	B MULTIPLE	M 10 x 1.5	10.9	50-55	
2.5	B SINGLE	M 12	8.8	70-75	
2.5	B MULTIPLE	M 12	10.9	75-80	
3	B	M 10	HEX. BOLT 10.9 HEX. SOCKET H.C.B. 12.9	47-51	
3.5	C	M 12	8.8	74-85	
3	H	M 14	10.9	BOLT 180 150-160 TIE ROD	

COMMON FORMULAS

$$C = \text{Input torque} = \frac{q \cdot \Delta p}{62.8 \cdot \eta_m} \text{ (Nm)}$$

$$P = \text{Input power} = \frac{q \cdot n \cdot \Delta p \cdot 10^{-3}}{600 \eta_m} \text{ (kW)}$$

$$Q = \text{Outlet flow} = \frac{q \cdot n \cdot \eta_v}{1000} \text{ (l/min)}$$

LEGENDA

Δp = Working pressure (bar)

q = Displacement (cm^3/rev)

n = Speed (min^{-1})

η_m = Mechanical eff. (0.92)

η_v = Volumetric eff. (0.95)

Description of the product identification label

Based on the firm certification ISO 9001 - UNI EN 29001, section 4.8 (identification and traceability of the product), we have adopted a new identification label starting from the 1st march 1995. Pls, see following example:

A			
B			
C		D	
E	salami	F	G

- A = Product short description (VD8A/FDD/U4G).**
- B = Customer part number.**
- C = Salami part number (6235 0025 0).**
- D = Production batch (for Salami management)**
- E = Rotation sense (only for pumps).**
- F = Manufacturing date (see data sheet here below)**
- G = Progressive number of assembling.**

Only for pumps 2PB and 2PZ (except triple 2PB) the identification product is marked on the top of the pump body as shown here below:



SALAMI 09/02
MADE IN ITALY 4010998
612271211 nr. 13
2PB 19S B25 B5

- Product short description. _____
- Salami part number and progressive number of assembling. _____
- Production code (for Salami management). _____
- Month and year of made: maybe in the future you can find this type of production date in the label beside too. _____
- Rotation sense. _____

	1990	1991	1992	1993	1994	1995	1996	1997	1998	1999	2000	2001	2002	2003	2004	2005
JANUARY	0A	1A	2A	3A	4A	5A	6A	7A	8M	9M	0M	1M	2M	3M	4M	5M
FEBRUARY	0B	1B	2B	3B	4B	5B	6B	7B	8N	9N	0N	1N	2N	3N	4N	5N
MARCH	0C	1C	2C	3C	4C	5C	6C	7C	8P	9P	0P	1P	2P	3P	4P	5P
APRIL	0D	1D	2D	3D	4D	5D	6D	7D	8Q	9Q	0Q	1Q	2Q	3Q	4Q	5Q
MAY	0E	1E	2E	3E	4E	5E	6E	7E	8R	9R	0R	1R	2R	3R	4R	5R
JUNE	0F	1F	2F	3F	4F	5F	6F	7F	8S	9S	0S	1S	2S	3S	4S	5S
JULY	0G	1G	2G	3G	4G	5G	6G	7G	8T	9T	0T	1T	2T	3T	4T	5T
AUGUST	0H	1H	2H	3H	4H	5H	6H	7H	8U	9U	0U	1U	2U	3U	4U	5U
SEPTEMBER	0I	1I	2I	3I	4I	5I	6I	7I	8V	9V	0V	1V	2V	3V	4V	5V
OCTOBER	0J	1J	2J	3J	4J	5J	6J	7J	8Z	9Z	0Z	1Z	2Z	3Z	4Z	5Z
NOVEMBER	0K	1K	2K	3K	4K	5K	6K	7K	8X	9X	0X	1X	2X	3X	4X	5X
DECEMBER	0L	1L	2L	3L	4L	5L	6L	7L	8Y	9Y	0Y	1Y	2Y	3Y	4Y	5Y



Rotation changing instructions for pumps GROUP 2 - 2.5 - 3 - 3.5

Before starting, be sure that the pump is cleaned externally as well as the working area to avoid that particles dangerous for pump working can find their way into the pump.

Pump represented is aclockwise rotation pump.

To obtain an anti_clockwise rotation read carefully the following instructions.

Picture "A"

- 1 - Loosen and fully unscrew the clamp bolts.
- 2 - Lay the pump on the working area in order to have the mounting flange turned upside.
- 3 - Coat the shaft extension with grease to avoid damaging the shaft seal.
- 4 - Remove the flange and lay it on the working area; verify that the seal is correctly located in the body seat.

Picture "B"

- 1 - Mark the position of the bushing and eventually the thrust plate, relative to the body.
- 2 - Remove the bushing, thrust plate and the driving gear taking care to avoid driven gear axial shifts.

Picture "C"

- 1 - Draw out the driven gear from its housing, taking care to avoid rear cover axial shifts.
- 2 - Re-locate the driven gear in the position previously occupied by the driving gear.

Picture "D"

- 1 - Re-locate the driving gear in the position previously occupied by the driven gear.

Picture "E"

- 1 - Replace the bushing and thrust plate taking care that:
 - marks are located as on the picture
 - surface containing the seal is visible
 - seal and its protection are correctly located

Picture "F"

- 1 - Clean body and mounting flange refaced surfaces.
- 2 - Verify that the two plugs are located in the body.
- 3 - Refit the mounting flange, turned 180° from its original position.
- 4 - Replace the clamp bolts and tighten crosswise evenly to a torque of 40 - 45 Nm for 2PB, 2.5PB, 45 - 50 Nm for 3PB, 3.5PB.
- 5 - Check that the shaft rotates freely.
- 6 - Mark on the flange the new direction of rotation.

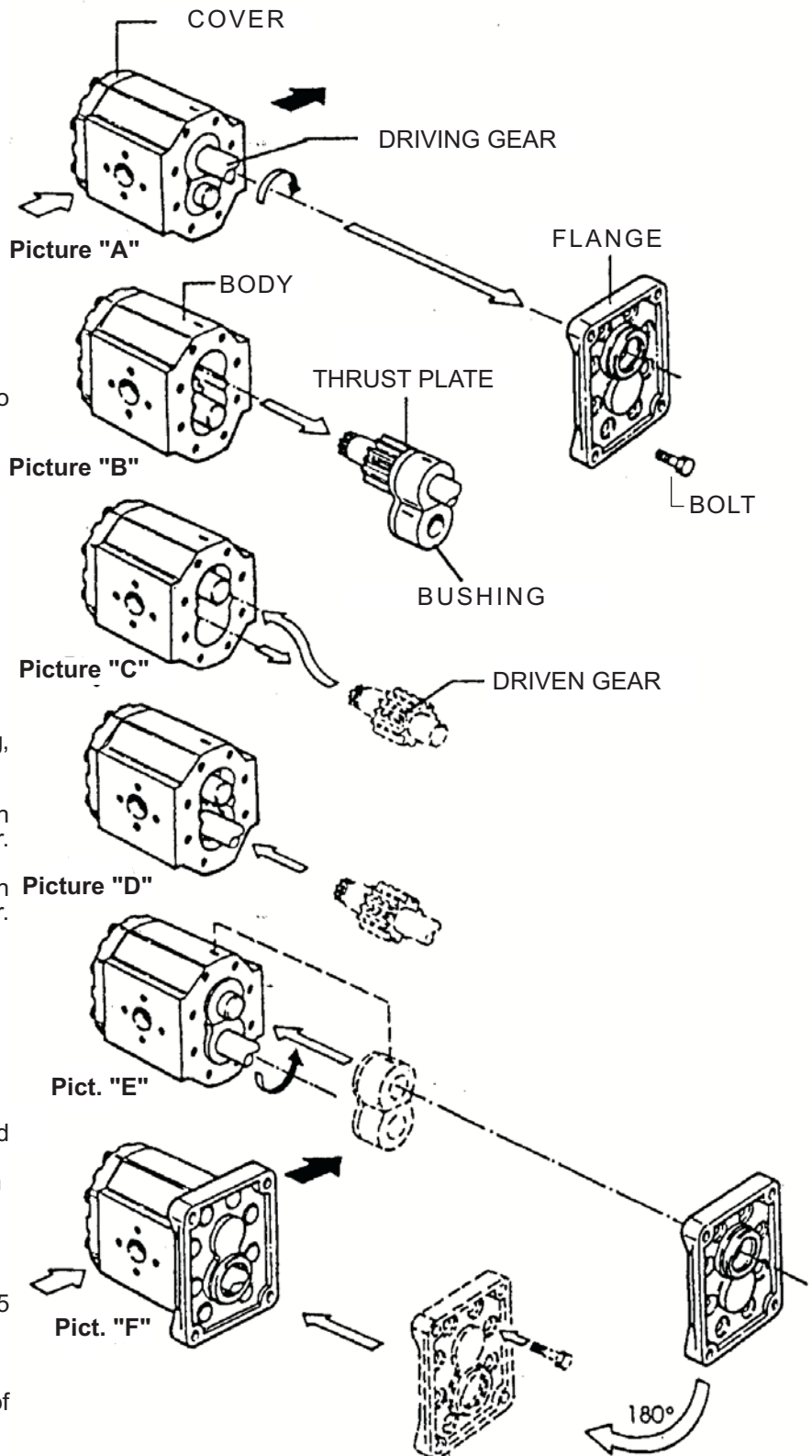

IMPORTANT: TO AVOID A PERFORMANCE LOSS DO NOT CHANGE MOTOR ROTATION

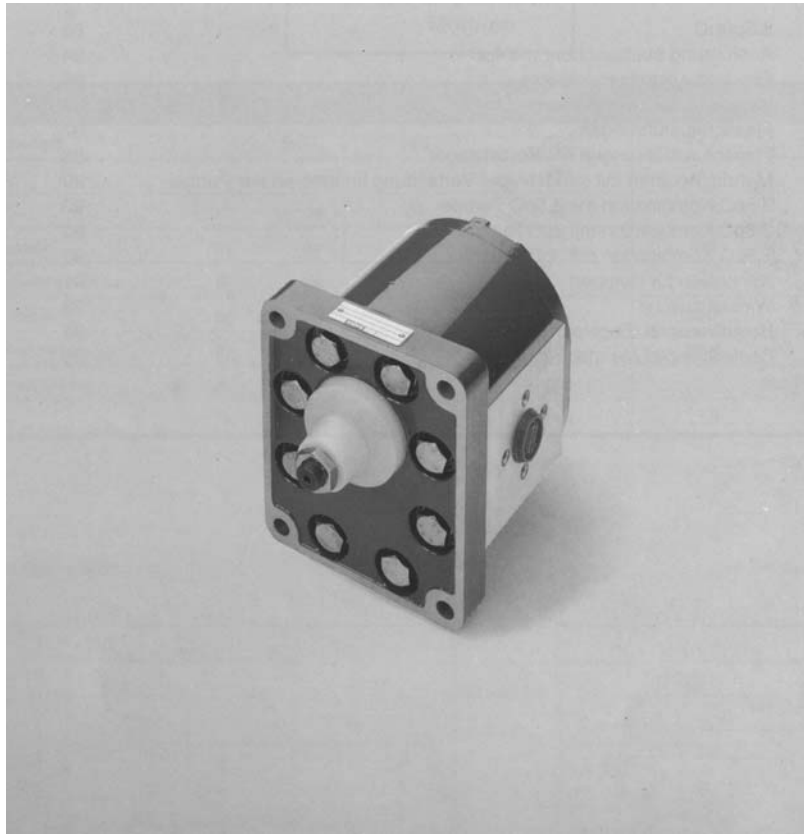

GEAR PUMP IN DETAIL

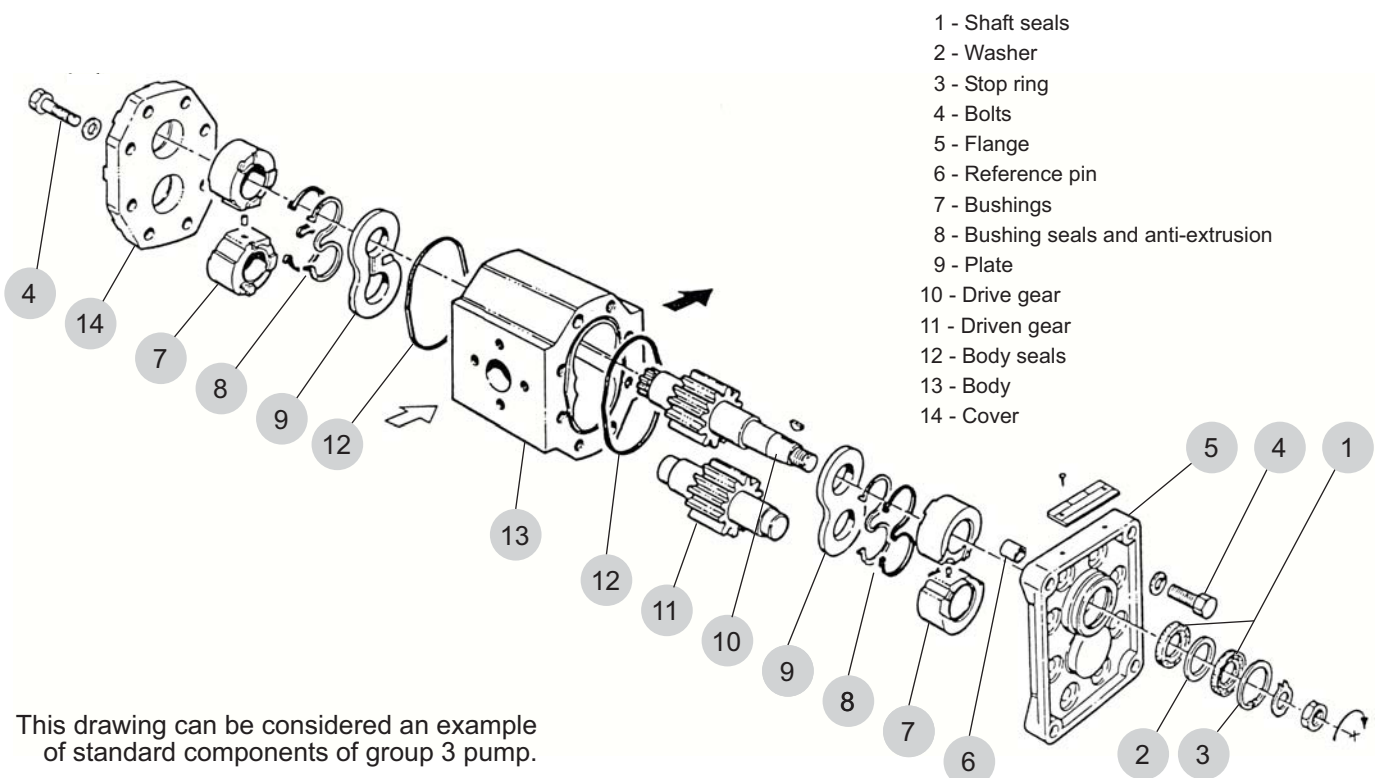

This drawing can be considered an example of standard components of group 3 pump.

GEAR PUMPS AND MOTORS "B" SERIES

3.5P/MC Group 3.5

Displacements up to 5.98 cu.in./rev
Pressure up to 4300 psi

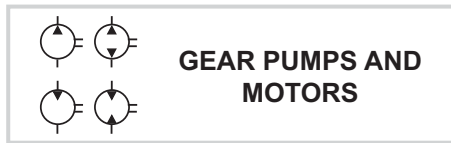

Displacements up to 98 cm³/rev
Pressure up to 300 bar

ASSEMBLING DIMENSIONS AND VALUES OF PRESSURE AND SPEED

Type			55	64	75	87	98*
Displacement	cm ³ /rev. cu.in./rev.		54.8 3.34	63.2 3.85	74.7 4.55	88 5.36	99 6.03
Dimension A	mm. in.		165 6.49	177 6.96	184 7.24	192 7.55	197 7.75
Dimension C	mm. in.		80 3.14	86 3.38	89.5 3.52	93.5 3.68	96 3.77
Working pressure	p1	bar psi	250 3600		230 3300	210 3000	200 2900
Intermittent pressure	p2	bar psi	280 4000		250 3600	230 3300	220 3140
Peak pressure	p3	bar psi	300 4300		280 4000	260 3750	250 3600
Max. speed at	p2	rpm	2750		2500	2250	2000
Min. speed at	p1	rpm	400	350	300		
Weight		kg lbs	10.7 23.54	11.4 25.08	11.9 26.18	12.5 27.5	12.8 27.5

*Available for quantity, please contact our sales dept.

Tightening torque 100 Nm

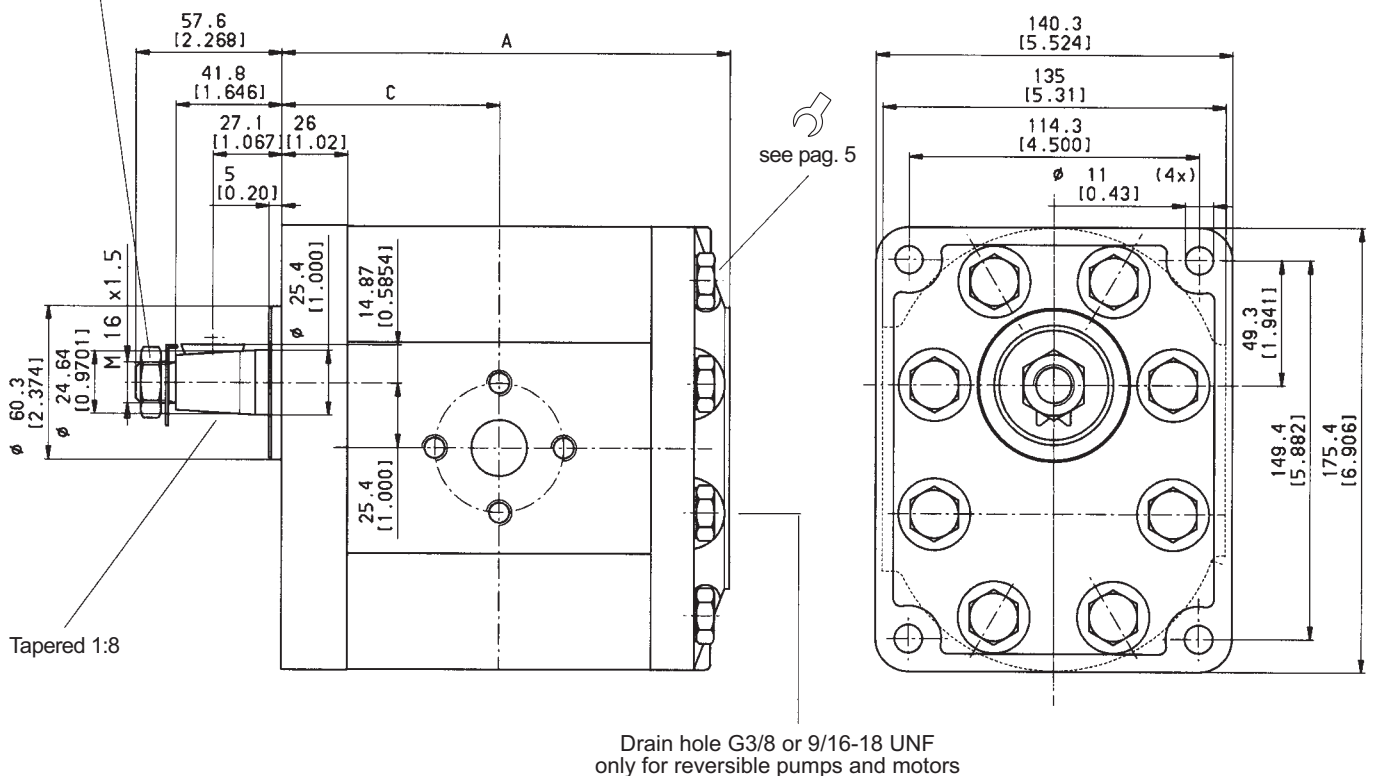

The pump shown is: **3.5PC 64D - P48 P3**

VERSION INTERCHANGEABLE WITH 4PB



**GEAR PUMPS AND
MOTORS**

3.5P/MC VERSION INTERCHANGEABLE WITH 4P/MB MEANS THAT THE FLANGE HAS THE SAME DISTANCE BETWEEN CENTER HOLES OF 4P/MB

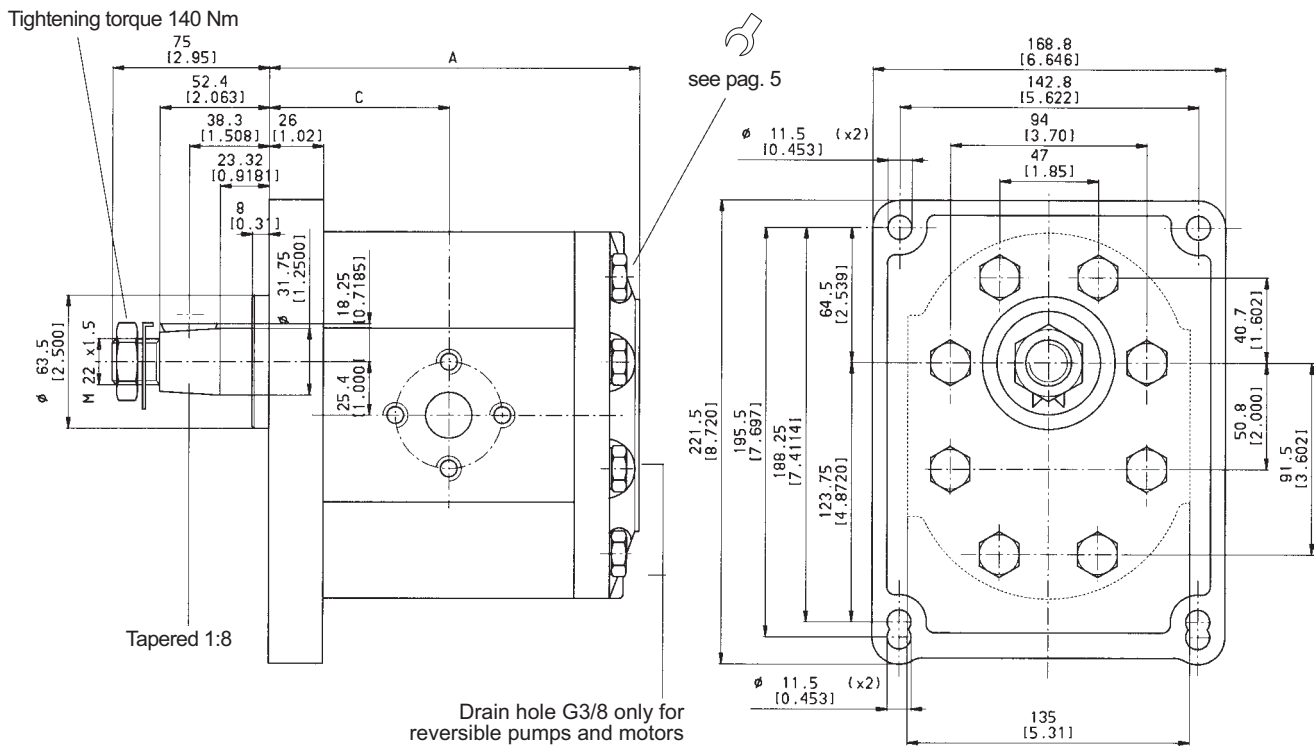

The pump shown is: **3.5PC 87D - P49 P4**

Type			75	87	98
Displacement		cm ³ /rev.	74.7	88	99
		cu.in./rev.	4.55	5.36	6.03
Dimension A		mm.	184	192	197
		in.	7.24	7.55	7.75
Dimension C		mm.	89.5	93.5	96
		in.	3.52	3.68	3.77
Working pressure	p1	bar	230	210	200
		psi	3300	3000	2900
Intermittent pressure	p2	bar	250	230	220
		psi	3600	3300	3140
Peak pressure	p3	bar	280	260	250
		psi	4000	3750	3600
Max. speed at	p2	rpm	2500	2250	2000
Min. speed at	p1	rpm	300		
Weight		kg	12.5	13	14
		lbs	27.5	28.6	30.8

FLANGED PORTS

For unidirectional motor inlet/outlet ports are reversed.

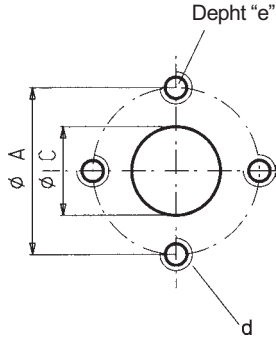

Type	INLET				OUTLET			
	ØA	ØC	d	e	A	ØC	d	e
55	51 (2.01")	27 (1.06")	M10	16 (0.63")	51 (2.01")	22 (0.87")	M10	16 (0.63")
64	62 (2.44")	33 (1.30")	M12	22 (0.86")				
75	72.5 (2.85")	38 (1.50")	M12	22 (0.86")	51 (2.01")	22 (0.87")	M10	16 (0.63")
87								
98								

code P

*For version 49 P4 (version interchangeable with 4PB see page 10)

Tightening torque for different threads:
M10: 50 Nm
M12: 90 Nm

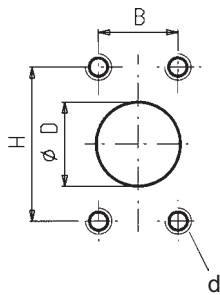

Type	INLET				OUTLET			
	ØD	H	B	d	ØD	H	B	d
55	32 (1.26")	58.7 (2.31")	30.2 (1.26")	7/16-14 UNC	19 (0.75")	47.6 (1.87")	22.22 (0.87")	3/8-16 UNC
64								
75	38 (1.50")	69.8 (2.75")	35.7 (1.41")		26 (1.02")	52.4 (2.06")	26.2 (1.03")	
87								
98								

code S

Available for quantity, please get in touch with our sales dept.

DRIVE SHAFTS

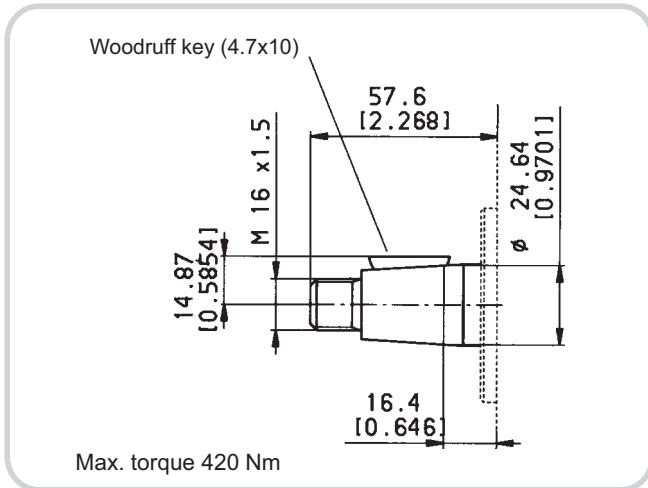

code 48 Tapered 1:8

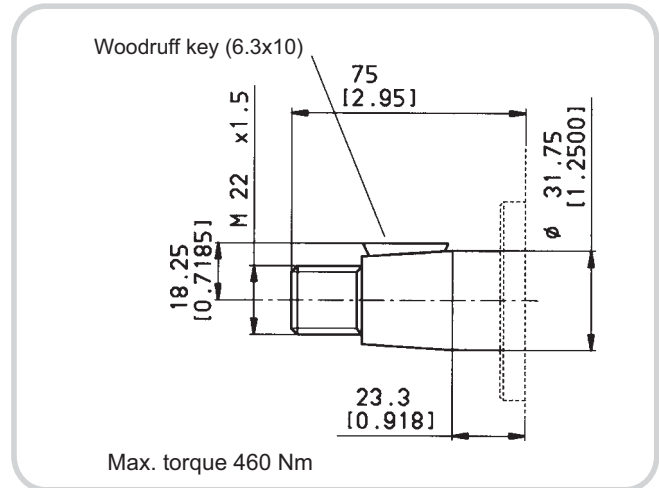

code 49 Tapered 1:8
Only with flange code P4

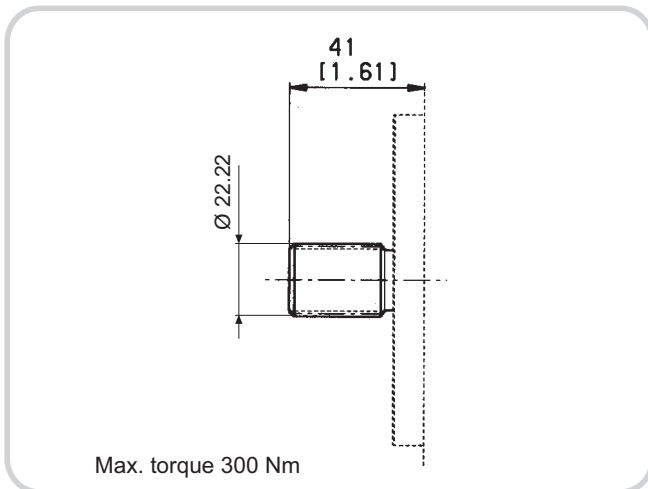

code 55 SAE B 13T-16/32DP - Ansi B92 1a 1976
Available for quantity, please contact our sales dept.

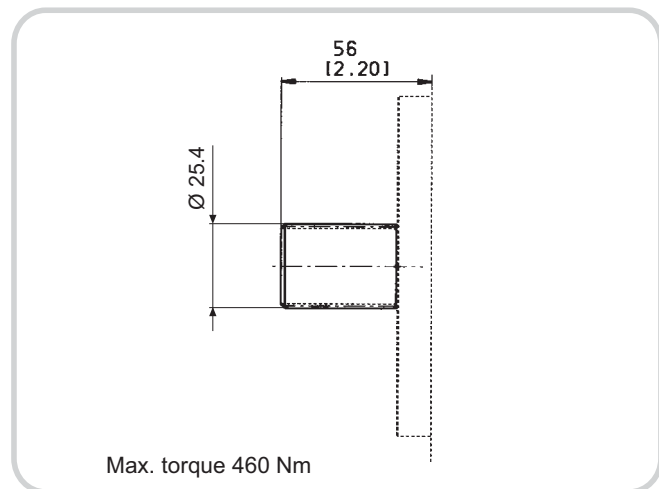

code 56 SAE BB 15T-16/32DP-Ansi B92 1a 1976
Available for quantity, please contact our sales dept.

MOUNTING FLANGES

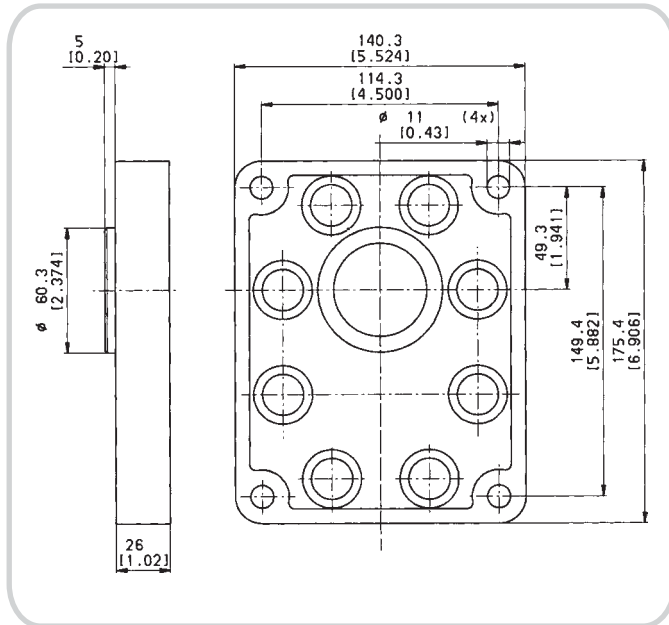

code P3 With shaft code 48

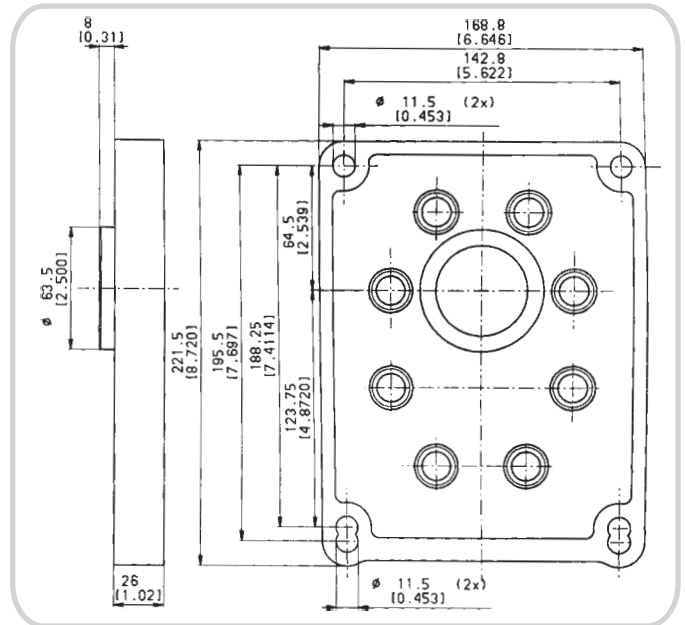

code P4 With shaft code 49

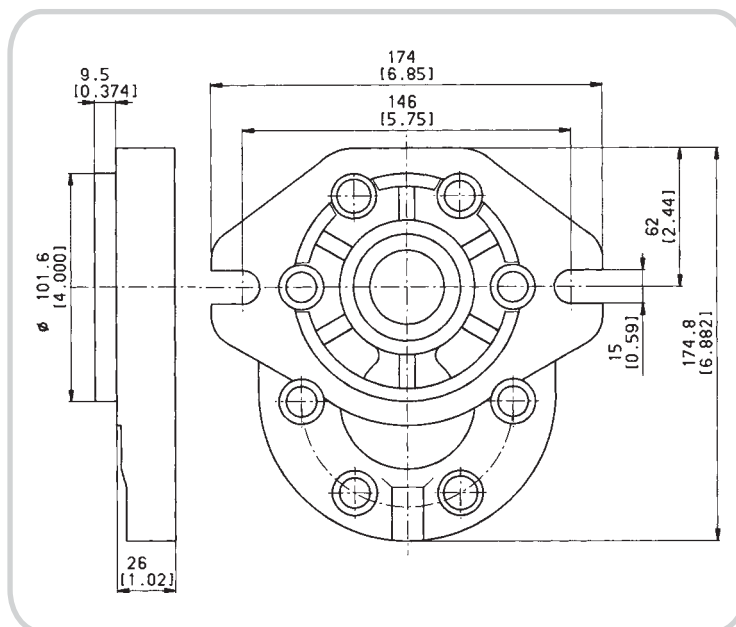

code S3 With shaft code 55 - 56
Available for quantity, please contact
our sales dept.

OUTRIGGER BEARING

Available for quantity, please contact our sales department

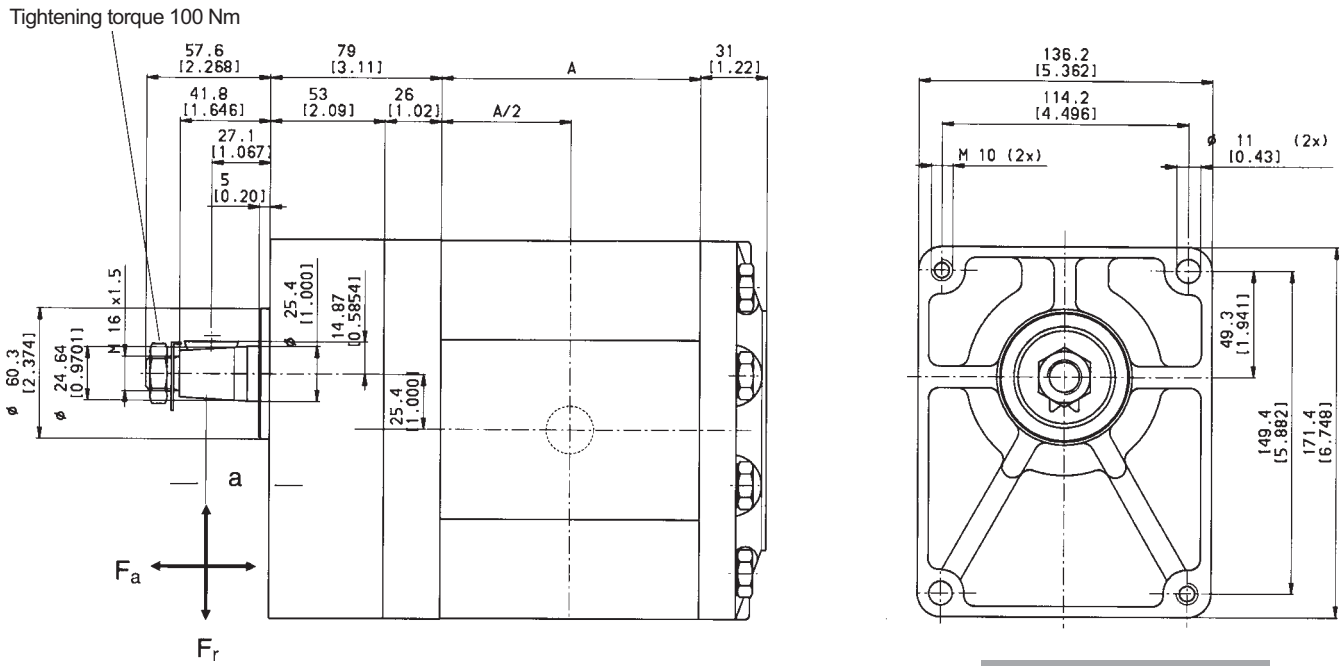

Example how to order: **3.5PC 87D - P48 P3 - CP**

For dimension "A" and performance data,
see corresponding single pumps (pag. 9)

Radial loads (daN)

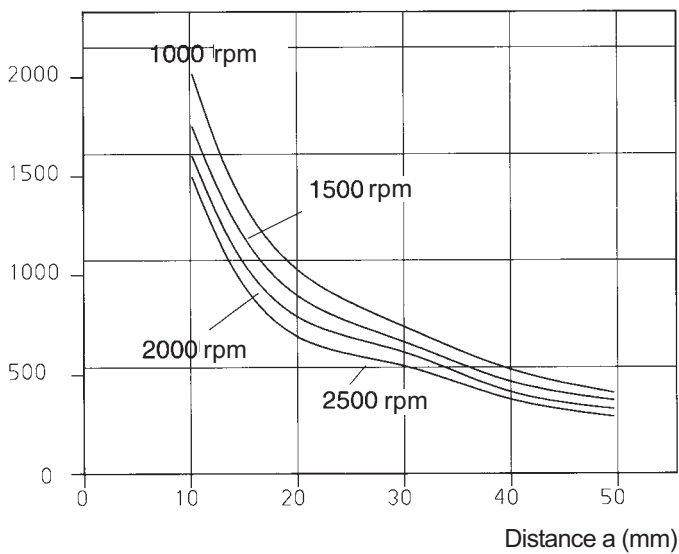

Distance from flange surface - Point at which the radial load acts F_r

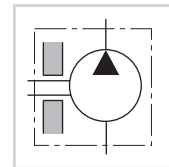

The diagram shows the maximum radial load with reference to a bearing life of 3000 hours.

To calculate the absorbed pump-torque or motor efficiency, please use the following formula:

$$C(\text{Nm}) = \frac{C_y \Delta p}{62.8}$$

C_y = Displacement pump

Δp = Pressure (bar/psi)

ASSEMBLING DIMENSIONS



Type		55	64	75	87	98
Displacement	cm ³ /rev.	54.8	63.2	74.7	88	99
	cu.in./rev.	3.34	3.85	4.55	5.36	6.03
Dimension A	mm.	108	120	127	135	140
	in.	4.25	4.72	5.00	5.31	5.51
Performance data		See corresponding single pumps				

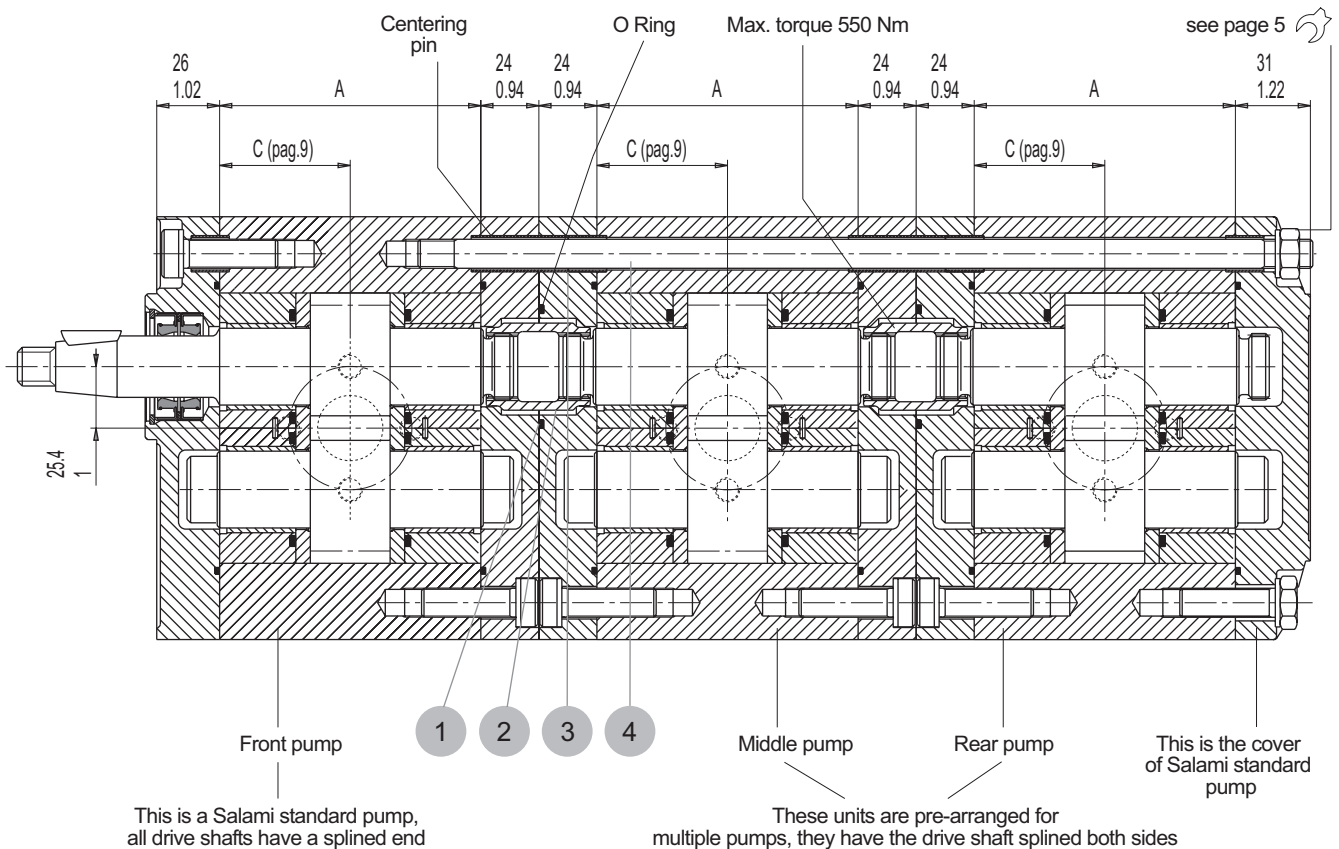

1 2 3 4 = kit multiple pumps

The **3PB** pumps can be easily transformed into front pump in the multiple units. All drive shafts are pre-arranged and have a splined end according DIN 5482. The first unit must always be the same size or bigger than following units. The features and performances are the same of the corresponding single units: only in the case of simultaneous operating you have to verify that the inlet torque is lower than the max. transmissible by the drive shaft.

Example to order : **3PC 75/64/55D - P48 P3**

3.5P/MC Group 3.5

GEAR PUMPS AND MOTORS "B" SERIES

3.5PC COMBINATION WITH 3PB PUMP (COMMUNICATING INLET PORTS)

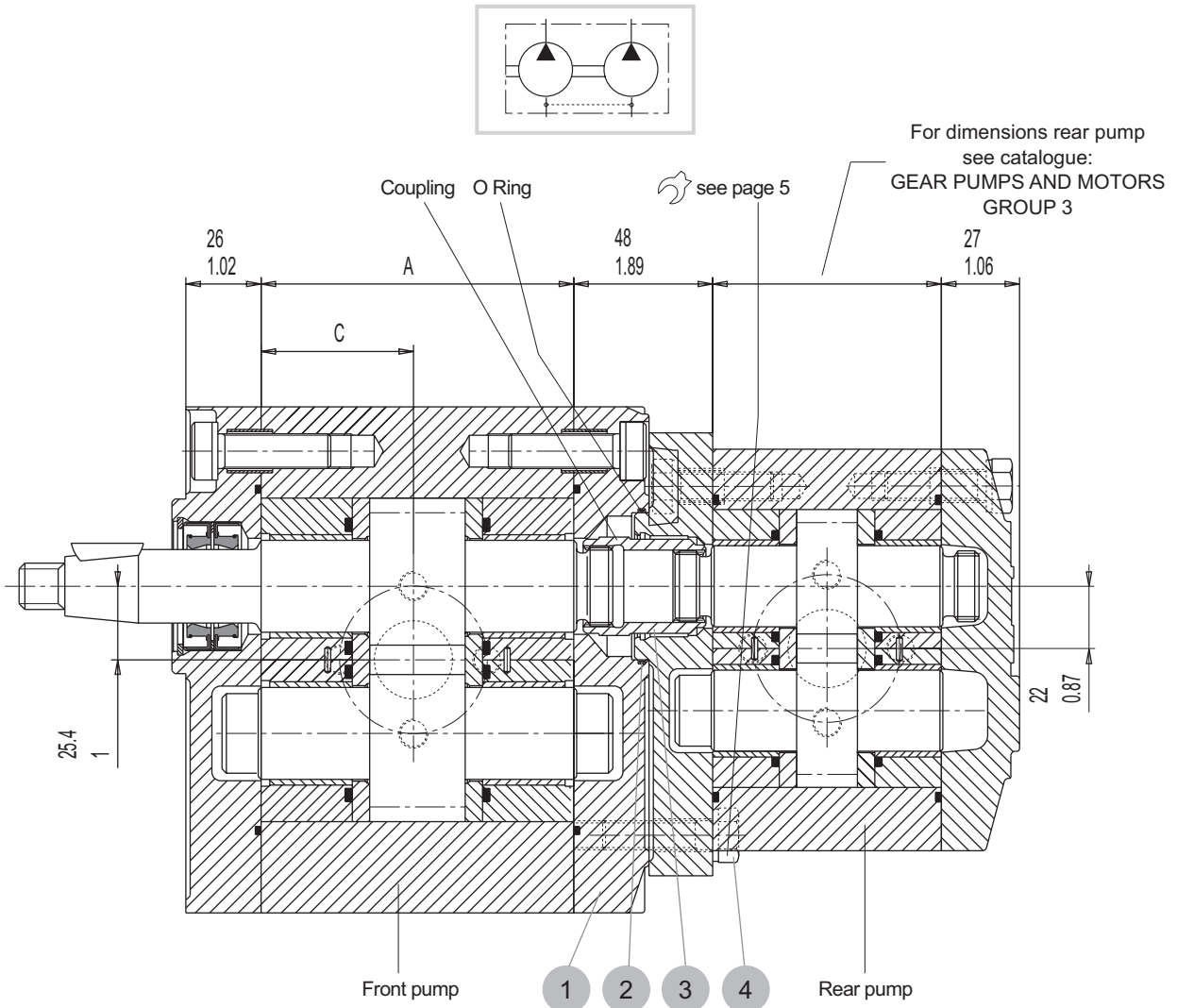

Order example:

3.5PC 64/3PB 21D - P48 P3

3.5PC 98/3PB 33S - P49 P4

3.5PC combination with
3PB (communicating inlet ports)
components kit:

- 1
- 2
- 3
- 4

For dimensions (A C) see corresponding multiple pumps page 15

3.5PC COMBINATION WITH 2PB PUMP (COMMUNICATING INLET PORTS)

Coupling O Ring see page 5

26 1.02 A C 45 1.77 24 0.94

25.4 15.9 0.63

Front pump 1 2 3 4 Rear pump

For dimensions rear pump see catalogue:
GEAR PUMPS AND MOTORS GROUP 2

3.5PC combination with 2PB (communicating inlet ports) components kit:

1 2 3 4

Order example:

3.5PC 46/2PB 16D - S55 S3

3.5PC 98/2PB 19S - P49 P4

For dimensions (A C) see corresponding multiple pumps page 15

3.5PC COMBINATION WITH 2PB PUMP WITH SEPARATED STAGES

Coupling O Ring Shaft seals see page 5

26 1.02 A C 61 2.40 24 0.94

25.4 15.9 0.63

Front pump 1 2 3 4 5 6 Rear pump

For dimensions and features rear pump see catalogue:
GEAR PUMPS AND MOTORS GROUP 2 (pag. 23 - 24)

3.5PC combination with 2PB (separated stages) components kit:

1 2 3 4 5 6

As you can see in the 2PB catalogue (pag. 24), drive shaft and assembling screws of the 2PB pump are longer than standard 2PB

code AS

Order example:

3.5PC 75/2PB 13.8D - P48 P3 - AS

For dimensions (A C) see corresponding multiple pumps page 15

3.5P/MC Group 3.5

A=250 bar (3600 psi) **D=140 bar (2000 psi)**
A1=230 bar (3300 psi) **E=105 bar (1500 psi)**
B=220 bar (3140 psi) **F=50 bar (725 psi)**
C=175 bar (2530 psi) **G=7 bar (100 psi)**

Performance curves carried out with oil viscosity at 16 cSt and oil temperature at 60°C

PUMP PERFORMANCE CURVES

Input power (kW)

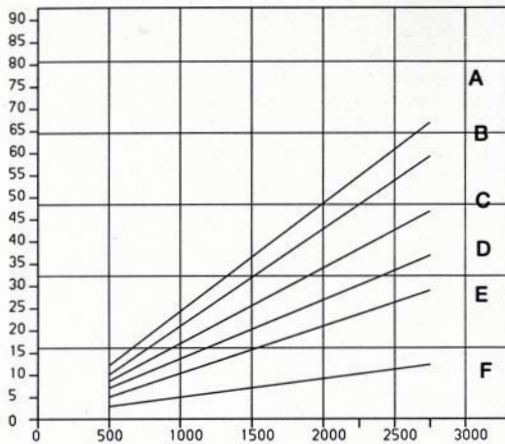

3.5PC 55

Shaft speed r.p.m

Flow
U.S. g p m

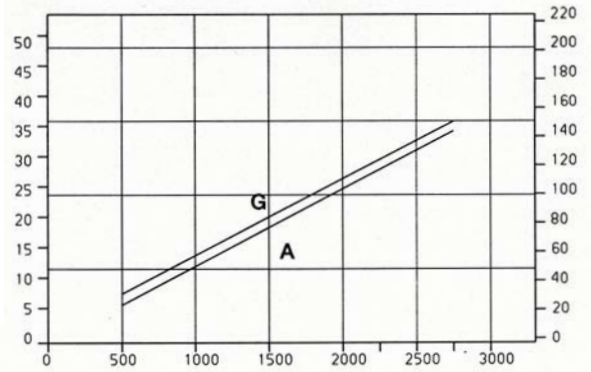

Flow
U.S. g p m

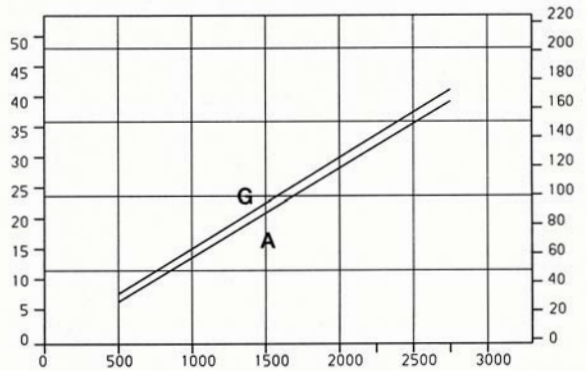

Input power (kW)

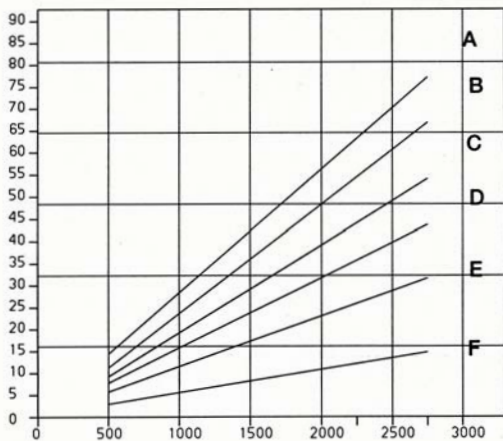

3.5PC 64

Shaft speed r.p.m

Flow
U.S. g p m

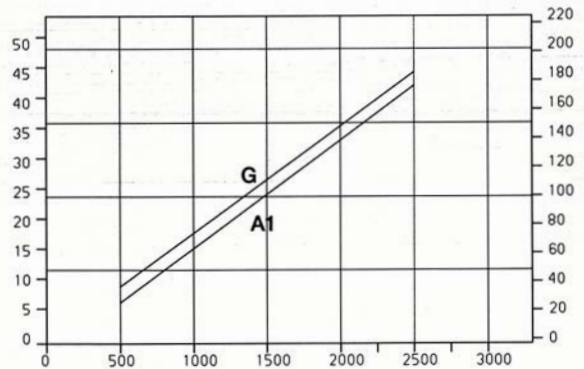

Input power (kW)

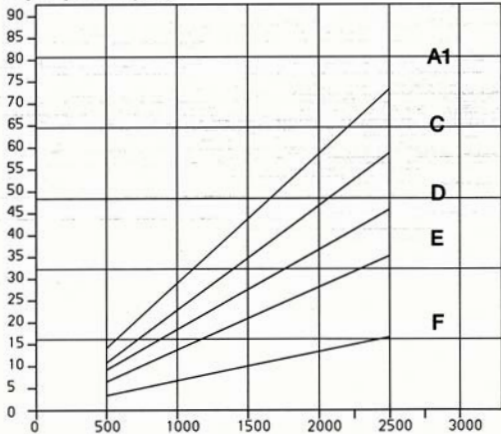

3.5PC 75

Shaft speed r.p.m

3.5P/MC Group 3.5

A=250 bar (3600 psi) **D=140 bar (2000 psi)**
A1=230 bar (3300 psi) **E=105 bar (1500 psi)**
B=220 bar (3140 psi) **F=50 bar (725 psi)**
C=175 bar (2530 psi) **G=7 bar (100 psi)**

Performance curves carried out with oil viscosity at 16 cSt and oil temperature at 60°C

Input power (kW)

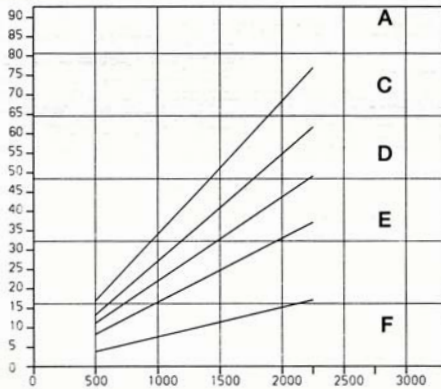

3.5PC 87

Shaft speed r.p.m

Flow

U.S. g p m

l/min

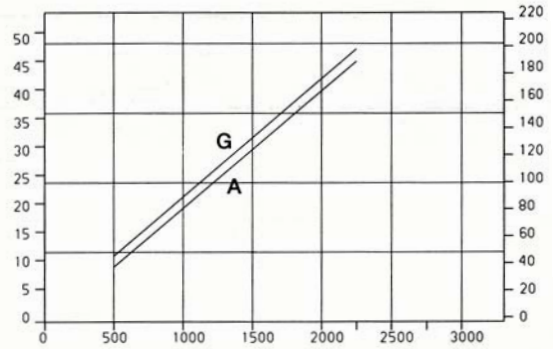

Input power (kW)

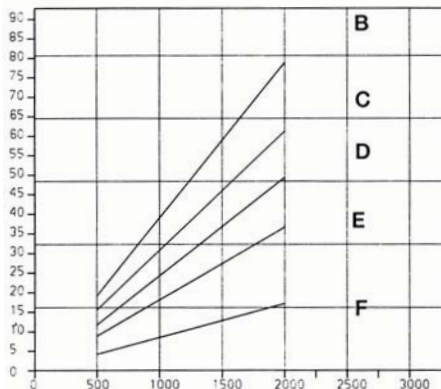

3.5PC 98

Shaft speed r.p.m

Flow

U.S. g p m

l/min

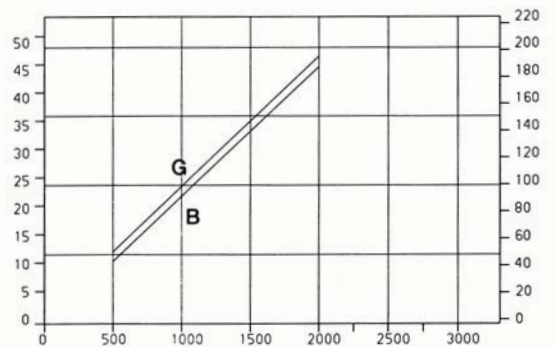

PORT CONNECTORS

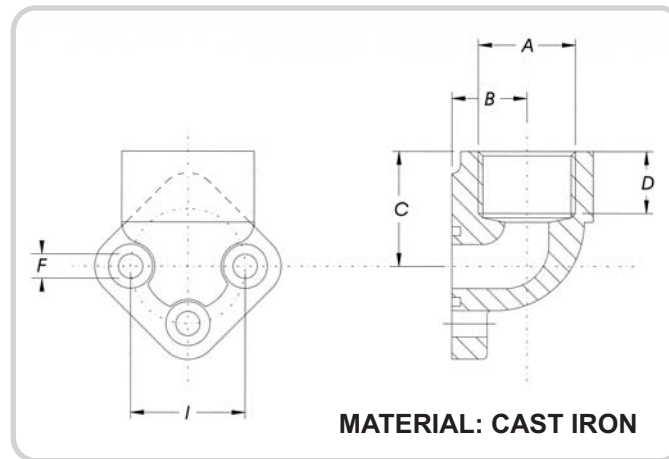

Type G

AVAILABLE CONNECTORS - DIMENSIONS AND CODE

Type	C	B	I	D	Ø F	Ø A	ORDERING CODE COMPLETE OF SCREW - SPRING WASHER - O RING
3 G	43	27	51	21	10.5	G 1	4352 7013 0
4 G	55	34.5	62	27	12.5	G 1 1/4	4352 7017 0
5 G	56	34.5	72.5	27	12.5	G 1 1/2	4352 7018 0

SINGLE PUMPS/MOTORS

3.5 P C 64 D - P 48 P3 - V - CP - PD2 - PD3

DIMENSION

FUNCTION	CODE
Pump	P
Motor	M

SERIES

TYPE	DISPLACEMENTS	
55	54.8 cm ³ /rev.	3.34 cu.in/rev.
64	63.2 cm ³ /rev.	3.85 cu.in/rev.
75	74.7 cm ³ /rev.	4.55 cu.in/rev.
87	88 cm ³ /rev.	5.36 cu.in/rev.
98*	99 cm ³ /rev.	6.03 cu.in/rev.

ROTATION	CODES
Clockwise	D
Anti-clockwise	S
Reversible	R

PORTS (pag. 11)	CODES
Flanged ports european standard	P
SAE flanged ports (UNC)	S*

PD3=pre-arranged for 3PB rear

PD2=pre-arranged for 2PB rear

OUTRIGGER BEARINGS (pag. 14)	CODES
European standard	CP*

SEAL	CODE
Buna Standard	
Viton	V

MOUNTING FLANGES (pag. 13)	CODES
European standard Ø 60.3	P2
European std. interchangeable with 4PB Ø 63.5	P3 (pag.11)
SAE B 2 bolts Ø 101.6	S3*

DRIVE SHAFTS (pag. 12)	CODES
Tapered 1:8 Ø 24.64	48
Tapered 1:8 Ø 31.75	49
SAE B splined 13 T	55*
SAE BB splined 15 T	56*

*Available for quantity, please contact our sales department

Example to order a 3.5 PC standard pump: 3.5PC 64D - P48 P3
 Example to order a 3.5 PC interchangeable with 4PB: 3.5PC 98D - P49 P4

MULTIPLE PUMPS

3.5PC 75 64 55 D - S 55 S3 - V - AS - CP - PD2 - PD3 3PB... / 2PB...

DIMENSION

TYPE	DISPLACEMENTS	
55	54.8 cm ³ /rev.	3.34 cu.in/rev.
64	63.2 cm ³ /rev.	3.85 cu.in/rev.
75	74.7 cm ³ /rev.	4.55 cu.in/rev.
87	88 cm ³ /rev.	5.36 cu.in/rev.
98*	99 cm ³ /rev.	6.03 cu.in/rev.

ROTATION	CODES
Clockwise	D
Anti-clockwise	S
Reversible	R

PORTS (pag. 11)	CODES
Flanged ports european standard	P
SAE flanged ports (UNC)	S*

DRIVE SHAFTS (pag. 12)	CODES
Tapered 1:8 Ø 24.64	48
Tapered 1:8 Ø 31.75	49
SAE B splined 13 T	55*
SAE BB splined 15 T	56*

See catalogues:
GEAR PUMPS AND MOTORS
"B" SERIES GROUP 3
GEAR PUMPS AND MOTORS
"B"SERIES GROUP 2

PD3=pre-arranged for 3PB rear

PD2=pre-arranged for 2PB rear

OUTRIGGER BEARINGS (pag. 14)	CODES
European standard	CP*

SUCTION TYPE (pag. 17)	CODES
3.5PC combination with 2PB with separated stages	AS

SEAL	CODE
Buna Standard	
Viton	V

MOUNTING FLANGES (pag. 13)	CODES
European standard Ø 60.3	P2
European std. interchangeable with 4PB Ø 63.5	P3 (pag.11)
SAE B 2 bolts Ø 101.6	S3*

*Available for quantity, please contact our sales department

Example to order a 3.5 PC tandem pump: 3.5PC 75/64D - S56 S3

Example to order a tandem pump 3.5PC combination with 3PB: 3.5PC 75/3PB 38S - P48 P3

Example to order a tandem pump 3.5PC combination with 2PB separated stages:

3.5PC 64/2PB 16D - P49 P4 - AS

WARRANTY

- We warrant products sold by us to be free from defects in material and workmanship.
- Our sole obligation to buyer under this warranty is the repair or replacement, at our option, of any products or parts thereof which, under normal use and proper maintenance, have proven defective in material or workmanship, this warranty does not cover ordinary wear and tear, abuse, misuse, overloading, alteration.
- No claims under this warranty will be valid unless buyer notifies SALAMI in writing within a reasonable time of the buyer's discovery of such defects, but in no event later than twelve (12) months from date of shipment to buyer.
- Our obligation under this warranty shall not include any transportation charges or cost of installation, replacement, field repair, or other charges related to returning products to us; or any liability for direct, indirect or consequential damage or delay. If requested by us, products or parts for which a warranty claim is made are to be returned transportation prepaid to our factory. The risk of loss of any products or parts thereof returned to SALAMI will be on buyer.
- No employee or representative is authorized to change any warranty in any way or grant any other warranty unless such change is made in writing and signed by an officer of SALAMI.



SALAMI spa
via Emilia Ovest 1006
41100 Modena Italy
telefono 059 387411
telex 059 387500
export@salami.it - www.salami.it



SALAMI ITALIA srl
strada Pelosa 183
S. Pietro in Trigogna VI Italy
telefono 0444 240080
telex 0444 240204
salami.italia@salami.it



SALAMI ESPAÑA
Poligono Industrial Armenteres
C/Primer de Maig, 18, Nave 4
08980 San Feliu de Llobregat
Barcelona
telefono 93-6327288
telex 93-6667826
salami1@terra.es



SALAMI FRANCE
22, rue Louis Saillant
69120 Vaulx en Velin
Lyon
telefono 04 78 80 99 41
telex 04 78 80 36 69
e.pasian@wanadoo.fr



149 S.O. Chenango St. Ext.,
GREEN, NY 13778
Tel.: 001-607-6565702
Fax.:001-607-6565704
info@salamihydraulics.com